

# Village of Goodrich Building Application Commercial/Residential

Building Department: 7338 S. State Road - Goodrich, Mi 48438  
Ph: 810 636-2570 Fax: 810 636-8886

Job Site Address \_\_\_\_\_

Lot/Parcel Number \_\_\_\_\_

Permit To:   \_\_\_ New       \_\_\_ Addition       \_\_\_ Alter/Remodel   \_\_\_ Code Compliance  
              \_\_\_ Pool       \_\_\_ Deck/Porch     \_\_\_ Accessory Building   \_\_\_ Demo  
              \_\_\_ Other (Describe): \_\_\_\_\_

Permit To:   \_\_\_ Residential Built Home       \_\_\_ Pre-Manufactured Home  
              \_\_\_ Commercial/Industrial     \_\_\_ Apartments  
              \_\_\_ Other \_\_\_\_\_

## Foundation Type

\_\_\_ Basement Block/Foam  
\_\_\_ Basement Poured  
\_\_\_ Basement Wood/Steel  
\_\_\_ Reinforced Mat  
\_\_\_ 42" Footings (Trench/Spread)  
\_\_\_ 42" Footings (Pole)  
\_\_\_ Crawl Space  
\_\_\_ Piers  
\_\_\_ Existing

## Construction Information

Commercial Sq Ft \_\_\_\_\_  
Deck Sq Ft \_\_\_\_\_  
Covered \_\_\_ Enclosed \_\_\_  
Building Height \_\_\_\_\_  
1<sup>st</sup> Floor \_\_\_\_\_ 2<sup>nd</sup> Floor \_\_\_\_\_  
Garage Sq Ft \_\_\_\_\_  
Finished Basement \_\_\_\_\_

Estimated Construction Value \_\_\_\_\_

**CONTINUE APPLICATION ON NEXT PAGE**

**BELOW FOR OFFICE USE ONLY**

Building Inspector Approval \_\_\_\_\_ Date \_\_\_\_\_ Remarks: \_\_\_\_\_  
1<sup>st</sup> Floor \_\_\_\_\_  
2<sup>nd</sup> Floor \_\_\_\_\_  
Finished Basement \_\_\_\_\_  
Attached Building \_\_\_\_\_  
Detached Building \_\_\_\_\_  
Porch: Open \_\_\_\_\_  
Covered \_\_\_\_\_  
Enclosed \_\_\_\_\_

Plan Review Fee \_\_\_\_\_

## **PLOT PLAN TO BE COMPLETED BY ALL APPLICANTS**

Please submit Approved Septic Site Plan From Health Department: Including the Following:

1. Location & dimensions of all property lines regardless of acreage, include North Point.
2. Location of public streets, highways, private drives, driveways, easements.
3. Location, dimensions and square footage of all existing and proposed buildings or other permanent structures; ie. pools, decks, ect.
4. Distance from all property lines to the proposed building or structure.
5. Location of all underground utilities, well, septic, storm or sanitary sewer, etc.
6. Location of any natural features ie. ponds, rivers, streams, drains.

Property Owner Name \_\_\_\_\_ Phone ( ) \_\_\_\_\_

Current Address \_\_\_\_\_ City \_\_\_\_\_ State \_\_\_\_\_ Zip \_\_\_\_\_

Owners Drivers License Number \_\_\_\_\_ or Date of Birth \_\_\_\_\_

**Property Owner Affidavit:** I hereby certify the work described on this permit application shall be installed in accordance with the State Code and shall not be enclosed, covered up or put into operation until it has been inspected and approved by the inspector. I will cooperate with the inspector and assume the responsibility to arrange for the necessary inspections.

Section 23a of the State Construction Code of 1972, Act No. 230 of the Public Acts of 1972, being Section 125.1523a of the Michigan Compiled Laws, prohibits a person from conspiring to circumvent the licensing requirements of the state relating to persons who are to perform work on a residential building or a residential structure. Violators of Section 23a are subject to civil fines.

Property Owner's Signature \_\_\_\_\_ Date \_\_\_\_\_

Contractor Name on License \_\_\_\_\_ Phone ( ) \_\_\_\_\_

Contractor License Number \_\_\_\_\_ Expiration Date \_\_\_\_\_

Current Address \_\_\_\_\_ City \_\_\_\_\_ State \_\_\_\_\_ Zip \_\_\_\_\_

Federal ID Number (or reason for exemption) \_\_\_\_\_

Workman's Comp. Carrier (or reason for exemption) \_\_\_\_\_

MESC Number (or reason for exemption) \_\_\_\_\_

**Contractor Affidavit:** I hereby certify that the proposed work is authorized by the owner to make this application as his authorized agent, and we agree to conform to all applicable laws of the State of Michigan and the local jurisdiction. All information on this application is accurate to the best of my knowledge.

Section 23a of the State Construction Code Act of 1972, Act NO. 230 of the Public Acts of 1972, being Section 125.1523a of the Michigan Compiled Laws, prohibits a person from conspiring to circumvent the licensing requirements of the state relating to persons who are to perform work on a residential building or a residential structure. Violators of Section 23a are subject to civil fines.

Contractor's Signature \_\_\_\_\_ Date \_\_\_\_\_

Print Name \_\_\_\_\_ Date \_\_\_\_\_

Architect or Engineer Name \_\_\_\_\_ Phone ( ) \_\_\_\_\_

Address \_\_\_\_\_ City \_\_\_\_\_ State \_\_\_\_\_ Zip \_\_\_\_\_

Signature \_\_\_\_\_ Date \_\_\_\_\_

Resolution 2022-12

**VILLAGE OF GOODRICH BUILDING PERMIT FEES**

A. **DWELLING**

**House**

*First Floor* \$90 per square foot

*Second Floor* \$80 per square foot

**Garage** \$35 per square foot

**Porch** \$30 per square foot

Any said costs for construction over \$350,000 will be based on the permit fee plus \$3.00 per 1,000 square feet.

B. **ADDITIONS**

1. \$370.00 + \$.10 per square foot

Any residential addition to a dwelling (including: bedroom, bathroom, family room etc.)

2. \$220.00 + \$.10 per square foot

Any residential addition to a dwelling/parcel (including: detached/attached garages, porches, decks etc.)

C. **REMODELING** (minimum permit fee \$225.00)

Where building permits are required for construction that do not involve an addition to, or expansion, of outside walls of the structure, or an increase in the occupied space, or when the construction is less than \$10,000.00.

Any said costs for construction over \$10,000.01 will be based on the minimum permit fee plus \$3.00 per each additional \$1,000.

D. **SHEDS** No building permit is required for a shed under 200 square feet but requires authorization from the Village Zoning Administrator.

E. **ACCESSARY BUILDINGS** \$235.00 + .10 per square foot

F. **SWIMMING POOLS**

Above Ground \$150.00 flat fee

In Ground \$225.00 flat fee

G. **FENCES**

No building permit required for fencing 6 feet and under but requires authorization from the Village Administrator.

H. **COMMERCIAL AND INDUSTRIAL BUILDING PERMIT FEES**

Commercial up to \$500,000.00 \$450.00 + .0050 x building cost \$500,000.01 and over  
\$450.00 + .0035 x building cost

*PLUS* Plan review up to \$500,000.00 (min \$200.00) .0013 x building cost

*PLUS* Plan review over \$500,000.01 (min \$650.00) .0015 x building cost

I. **MOVING OF STRUCTURES**

Pre-moving application fee and site plan \$150.00  
(Building permit and bonds as required)

J. **DEMOLITION OF STRUCTURE**

|                            |  |
|----------------------------|--|
| Sheds, Garages & Accessory | \$60.00  |
| One & Two Family Homes     | \$150.00 + \$5.00 per 1,000 square feet or part there of |
| Commercial                 | \$150.00 + \$5.00 per 1,000 square feet or part there of |

K. **SIGN PERMITS**

MUST RECEIVE APPROVAL BY THE VILLAGE ADIMINISTRATOR  
PRIOR TO RECEIVING A PERMIT

Permanent Sign \$70.00 PLUS \$75.00 staking inspection if needed

**\*\*PERMIT FEE SHALL BE DOUBLED IF SIGN IS ERECTED PRIOR TO ISSUANCEOF PERMIT\*\***

**ALLOWABLE TEMPORARY SIGN (SANDWICH BOARD) MUST RECEIVE  
APPROVAL FROM THE VILLAGE ADMINISTRATOR**

L. **RE-INSPECTIONS** \$75.00 PER INSPECTION

If a building inspection is requested and, in the opinion of the Building Inspector, the work is found to be either unacceptable or not ready for such inspection a re-inspection fee shall be paid to the Village of Goodrich before any such re-inspection is made.

M. **REMOVAL OF STOP WORK ORDER** \$120.00

N. **CULVERT INSPECTIONS** \$15.00  
(excluding M-15 and Green Road) ISSUED BY THE DEPARTMENT OF PUBLIC WORKS

O. **TEMPORARY LIVING QUARTERS** (One [1] year maximum)  
\$65.00 Permit Fee – Issued only under special circumstances.

P. **ROOF PERMIT** \$75.00 A ladder must be provided for inspector.  
If no ladder is present an additional \$75.00 inspection fee will be assessed.

Q. **PERMIT RENEWAL** \$55 (One [1] year)

YEAS: 5  
NAYS: 0  
ABSENT: 0

**RESOLUTION DECLARED ADOPTED**

*I, Sheri Wilkerson, the duly appointed Administrator and Clerk of the Village of Goodrich, do hereby CERTIFY that the foregoing is a true and accurate copy of Resolution 2022-12 that was adopted by the Village of Goodrich Council, Genesee County, Michigan at a regular meeting held June 13, 2022, the original of which is on file in my office and available to the public.*

Village of Goodrich Council

  
Sheri Wilkerson, Administrator/Clerk

Resolution Number: 2022-12  
Presented: July 11, 2022  
Adopted: July 11, 2022

Residential Building Permit Fees (Effective 7-11-22)

Village of Goodrich

| Cost<br>In (000) | Permit<br>Cost |
|------------------|----------------|
| 1                | \$95           |
| 2                | \$100          |
| 3                | \$106          |
| 4                | \$111          |
| 5                | \$167          |
| 6                | \$173          |
| 7                | \$178          |
| 8                | \$184          |
| 9                | \$189          |
| 10               | \$195          |
| 11               | \$201          |
| 12               | \$206          |
| 13               | \$212          |
| 14               | \$217          |
| 15               | \$223          |
| 16               | \$229          |
| 17               | \$233          |
| 18               | \$238          |
| 19               | \$242          |
| 20               | \$247          |
| 21               | \$352          |
| 22               | \$356          |
| 23               | \$361          |
| 24               | \$365          |
| 25               | \$370          |
| 26               | \$375          |
| 27               | \$379          |
| 28               | \$384          |
| 29               | \$388          |
| 30               | \$393          |
| 31               | \$398          |
| 32               | \$402          |
| 33               | \$407          |
| 34               | \$411          |
| 35               | \$416          |
| 36               | \$421          |
| 37               | \$425          |
| 38               | \$430          |
| 39               | \$434          |
| 40               | \$439          |
| 41               | \$444          |
| 42               | \$448          |
| 43               | \$453          |
| 44               | \$457          |
| 45               | \$462          |
| 46               | \$467          |
| 47               | \$471          |
| 48               | \$476          |
| 49               | \$480          |
| 50               | \$485          |
| 51               | \$490          |
| 52               | \$494          |
| 53               | \$499          |
| 54               | \$503          |
| 55               | \$508          |
| 56               | \$513          |
| 57               | \$517          |
| 58               | \$522          |
| 59               | \$526          |
| 60               | \$531          |
| 61               | \$532          |
| 62               | \$536          |
| 63               | \$541          |
| 64               | \$546          |
| 65               | \$551          |
| 66               | \$555          |
| 67               | \$560          |
| 68               | \$565          |
| 69               | \$569          |
| 70               | \$574          |

| Cost<br>In (000) | Permit<br>Cost |
|------------------|----------------|
| 71               | \$ 579         |
| 72               | \$ 583         |
| 73               | \$ 588         |
| 74               | \$ 593         |
| 75               | \$ 598         |
| 76               | \$ 602         |
| 77               | \$ 607         |
| 78               | \$ 612         |
| 79               | \$ 616         |
| 80               | \$ 621         |
| 81               | \$ 626         |
| 82               | \$ 630         |
| 83               | \$ 635         |
| 84               | \$ 640         |
| 85               | \$ 645         |
| 86               | \$ 649         |
| 87               | \$ 654         |
| 88               | \$ 659         |
| 89               | \$ 663         |
| 90               | \$ 668         |
| 91               | \$ 673         |
| 92               | \$ 677         |
| 93               | \$ 682         |
| 94               | \$ 687         |
| 95               | \$ 692         |
| 96               | \$ 696         |
| 97               | \$ 702         |
| 98               | \$ 706         |
| 99               | \$ 710         |
| 100              | \$ 725         |
| 101              | \$ 1,430       |
| 102              | \$ 1,435       |
| 103              | \$ 1,439       |
| 104              | \$ 1,444       |
| 105              | \$ 1,449       |
| 106              | \$ 1,454       |
| 107              | \$ 1,459       |
| 108              | \$ 1,463       |
| 109              | \$ 1,468       |
| 110              | \$ 1,473       |
| 111              | \$ 1,478       |
| 112              | \$ 1,483       |
| 113              | \$ 1,487       |
| 114              | \$ 1,492       |
| 115              | \$ 1,497       |
| 116              | \$ 1,502       |
| 117              | \$ 1,507       |
| 118              | \$ 1,511       |
| 119              | \$ 1,516       |
| 120              | \$ 1,521       |
| 121              | \$ 1,538       |
| 122              | \$ 1,543       |
| 123              | \$ 1,548       |
| 124              | \$ 1,553       |
| 125              | \$ 1,558       |
| 126              | \$ 1,562       |
| 127              | \$ 1,567       |
| 128              | \$ 1,572       |
| 129              | \$ 1,577       |
| 130              | \$ 1,582       |
| 131              | \$ 1,587       |
| 132              | \$ 1,592       |
| 133              | \$ 1,597       |
| 134              | \$ 1,602       |
| 135              | \$ 1,607       |
| 136              | \$ 1,611       |
| 137              | \$ 1,616       |
| 138              | \$ 1,621       |
| 139              | \$ 1,626       |
| 140              | \$ 1,631       |

| Cost<br>In (000) | Permit<br>Cost |
|------------------|----------------|
| 141              | \$1,636        |
| 142              | \$1,641        |
| 143              | \$1,646        |
| 144              | \$1,651        |
| 145              | \$1,656        |
| 146              | \$1,660        |
| 147              | \$1,665        |
| 148              | \$1,670        |
| 149              | \$1,675        |
| 150              | \$1,680        |
| 151              | \$1,685        |
| 152              | \$1,690        |
| 153              | \$1,695        |
| 154              | \$1,700        |
| 155              | \$1,705        |
| 156              | \$1,709        |
| 157              | \$1,714        |
| 158              | \$1,719        |
| 159              | \$1,724        |
| 160              | \$1,729        |
| 161              | \$1,734        |
| 162              | \$1,739        |
| 163              | \$1,744        |
| 164              | \$1,749        |
| 165              | \$1,754        |
| 166              | \$1,758        |
| 167              | \$1,763        |
| 168              | \$1,768        |
| 169              | \$1,773        |
| 170              | \$1,778        |
| 171              | \$1,783        |
| 172              | \$1,788        |
| 173              | \$1,793        |
| 174              | \$1,798        |
| 175              | \$1,803        |
| 176              | \$1,807        |
| 177              | \$1,812        |
| 178              | \$1,817        |
| 179              | \$1,822        |
| 180              | \$1,827        |
| 181              | \$1,832        |
| 182              | \$1,837        |
| 183              | \$1,842        |
| 184              | \$1,847        |
| 185              | \$1,852        |
| 186              | \$1,856        |
| 187              | \$1,861        |
| 188              | \$1,866        |
| 189              | \$1,871        |
| 190              | \$1,876        |
| 191              | \$1,881        |
| 192              | \$1,886        |
| 193              | \$1,891        |
| 194              | \$1,896        |
| 195              | \$1,901        |
| 196              | \$1,905        |
| 197              | \$1,910        |
| 198              | \$1,915        |
| 199              | \$1,920        |
| 200              | \$1,925        |
| 201              | \$1,930        |
| 202              | \$1,935        |
| 203              | \$1,940        |
| 204              | \$1,945        |
| 205              | \$1,950        |
| 206              | \$1,954        |
| 207              | \$1,959        |
| 208              | \$1,964        |
| 209              | \$1,969        |
| 210              | \$1,974        |

| Cost<br>In (000) | Permit<br>Cost |
|------------------|----------------|
| 211              | \$2,000        |
| 212              | \$2,005        |
| 213              | \$2,010        |
| 214              | \$2,015        |
| 215              | \$2,020        |
| 216              | \$2,025        |
| 217              | \$2,030        |
| 218              | \$2,035        |
| 219              | \$2,040        |
| 220              | \$2,045        |
| 221              | \$2,050        |
| 222              | \$2,055        |
| 223              | \$2,060        |
| 224              | \$2,065        |
| 225              | \$2,070        |
| 226              | \$2,075        |
| 227              | \$2,080        |
| 228              | \$2,085        |
| 229              | \$2,090        |
| 230              | \$2,095        |
| 231              | \$2,100        |
| 232              | \$2,105        |
| 233              | \$2,110        |
| 234              | \$2,115        |
| 235              | \$2,120        |
| 236              | \$2,125        |
| 237              | \$2,130        |
| 238              | \$2,135        |
| 239              | \$2,140        |
| 240              | \$2,145        |
| 241              | \$2,150        |
| 242              | \$2,155        |
| 243              | \$2,160        |
| 244              | \$2,165        |
| 245              | \$2,170        |
| 246              | \$2,175        |
| 247              | \$2,180        |
| 248              | \$2,185        |
| 249              | \$2,190        |
| 250              | \$2,195        |
| 251              | \$2,200        |
| 252              | \$2,205        |
| 253              | \$2,210        |
| 254              | \$2,215        |
| 255              | \$2,220        |
| 256              | \$2,225        |
| 257              | \$2,230        |
| 258              | \$2,235        |
| 259              | \$2,240        |
| 260              | \$2,245        |
| 261              | \$2,250        |
| 262              | \$2,255        |
| 263              | \$2,260        |
| 264              | \$2,265        |
| 265              | \$2,270        |
| 266              | \$2,275        |
| 267              | \$2,280        |
| 268              | \$2,285        |
| 269              | \$2,290        |
| 270              | \$2,295        |
| 271              | \$2,300        |
| 272              | \$2,305        |
| 273              | \$2,310        |
| 274              | \$2,315        |
| 275              | \$2,320        |
| 276              | \$2,325        |
| 277              | \$2,330        |
| 278              | \$2,335        |
| 279              | \$2,340        |
| 280              | \$2,345        |

| Cost<br>In (000) | Permit<br>Cost |
|------------------|----------------|
| 281              | \$ 2,350       |
| 282              | \$ 2,355       |
| 283              | \$ 2,360       |
| 284              | \$ 2,365       |
| 285              | \$ 2,370       |
| 286              | \$ 2,375       |
| 287              | \$ 2,380       |
| 288              | \$ 2,385       |
| 289              | \$ 2,390       |
| 290              | \$ 2,395       |
| 291              | \$ 2,400       |
| 292              | \$ 2,405       |
| 293              | \$ 2,410       |
| 294              | \$ 2,415       |
| 295              | \$ 2,420       |
| 296              | \$ 2,425       |
| 297              | \$ 2,430       |
| 298              | \$ 2,435       |
| 299              | \$ 2,440       |
| 300              | \$ 2,445       |
| 301              | \$ 2,450       |
| 302              | \$ 2,455       |
| 303              | \$ 2,460       |
| 304              | \$ 2,465       |
| 305              | \$ 2,470       |
| 306              | \$ 2,475       |
| 307              | \$ 2,480       |
| 308              | \$ 2,485       |
| 309              | \$ 2,490       |
| 310              | \$ 2,495       |
| 311              | \$ 2,500       |
| 312              | \$ 2,505       |
| 313              | \$ 2,510       |
| 314              | \$ 2,515       |
| 315              | \$ 2,520       |
| 316              | \$ 2,525       |
| 317              | \$ 2,530       |
| 318              | \$ 2,535       |
| 319              | \$ 2,540       |
| 320              | \$ 2,545       |
| 321              | \$ 2,550       |
| 322              | \$ 2,555       |
| 323              | \$ 2,560       |
| 324              | \$ 2,565       |
| 325              | \$ 2,570       |
| 326              | \$ 2,575       |
| 327              | \$ 2,580       |
| 328              | \$ 2,585       |
| 329              | \$ 2,590       |
| 330              | \$ 2,595       |
| 331              | \$ 2,600       |
| 332              | \$ 2,605       |
| 333              | \$ 2,610       |
| 334              | \$ 2,615       |
| 335              | \$ 2,620       |
| 336              | \$ 2,625       |
| 337              | \$ 2,630       |
| 338              | \$ 2,635       |
| 339              | \$ 2,640       |
| 340              | \$ 2,645       |
| 341              | \$ 2,650       |
| 342              | \$ 2,655       |
| 343              | \$ 2,660       |
| 344              | \$ 2,665       |
| 345              | \$ 2,670       |
| 346              | \$ 2,675       |
| 347              | \$ 2,680       |
| 348              | \$ 2,685       |
| 349              | \$ 2,690       |
| 350              | \$ 2,695       |

**Example**

House 1st floor                      1200 sq ft x \$90 = 108,000

---

House 2nd floor                      500 sq ft x \$80 = 40,000

---

Garage                                      400 sq ft x \$35 = 14,000

---

Porch                                      60 sq ft x \$30 = 1,800

---

Add totals 108,000 + 40,000 + 14,000 + 1,800

**Grand Total = 163,800**

Round up from 163,800 to 164,000

Find COST LINE 164 and the permit amount will be \$1,749

# VILLAGE OF GOODRICH BUILDING DEPARTMENT

## ITEMS REQUIRED FOR BUILDING PERMIT

### RESIDENTIAL CONSTRUCTION

1. TWO COMPLETE SETS OF PRINTS (SHOWING ALL REVISIONS / ADDITIONS / DELETIONS).
2. LEGAL DESCRIPTION OF PROPERTY, COPY OF DEED / LAND CONTRACT, AND COPY OF LAND SURVEY.
3. SEPTIC PERMIT FROM COUNTY HEALTH DEPARTMENT (YELLOW COPY) OR SEWER (B) PERMIT AND COUNTY CCIF PERMIT.
4. CULVERT PERMIT.
5. PLOT PLAN (DRAWN TO SCALE) SHOWING DIMENSIONS OF PROPERTY, ALL SETBACKS, LOCATION OF WELL, SEPTIC, DRIVEWAYS, OTHER BUILDINGS, AND ANY OTHER SIGNIFICANT FEATURES.
6. SOIL EROSION PERMIT FROM GENESEE COUNTY DRAIN COMMISSION.
7. COMPLETED CONTRACTOR INFORMATION FORM.
8. NAME, ADDRESS AND PHONE NUMBER OF PROPERTY OWNER.
9. ALL RESTRICTIONS AND / OR COVENANTS WHICH APPLY TO THE PROPERTY.
10. WELL PERMIT (YELLOW COPY).
11. PROOF OF OWNERSHIP OR PROPERTY TRANSFER AFFIDAVIT.

**NO CONSTRUCTION SHALL BE STARTED  
UNTIL APPROVAL IS GIVEN BY THE BUILDING INSPECTOR**

### REQUIRED INSPECTIONS

1. SITE INSPECTION.
2. FOOTING INSPECTION: BEFORE BEING POURED.
3. BACKFILL INSPECTION: PEA ROCK, TILE, T'S, AND DAMP-PROOFING.
4. ROUGH INSPECTION: AFTER ALL ROUGH ELECTRICAL, MECHANICAL AND PLUMBING INSPECTIONS HAVE BEEN COMPLETED BY STATE INSPECTORS.
5. INSULATION INSPECTION.
6. VISQUEEN / FLOOR (BASEMENT): SAND, PEA ROCK, AND TILE.
7. FINAL INSPECTION FOR OCCUPANCY PERMIT: AFTER ALL FINAL ELECTRICAL, MECHANICAL AND PLUMBING INSPECTIONS HAVE BEEN COMPLETED BY STATE INSPECTORS, AND AFTER FINAL SEPTIC SYSTEM APPROVAL HAS BEEN RECEIVED FROM THE COUNTY HEALTH DEPARTMENT OR SEWER INSPECTION REPORT HAS BEEN RECEIVED FROM WATER AND WASTE.

**NOTE: RE-INSPECTION FEE MAY BE CHARGED IF PROJECT IS NOT READY, OR DOES NOT PASS. MINIMUM FEE IS \$75 AND MUST BE PAID PRIOR TO RE-INSPECTION BEING PERFORMED.**

**\*\*\* You must have proof of a sewer inspection from Genesee County before your final building inspection \*\*\***

**\*\*\* Please include a proof of ownership or property transfer affidavit \*\*\***



**VILLAGE OF GOODRICH**  
**BUILDING INSPECTOR**  
7338 S STATE ROAD  
PO BOX 276  
GOODRICH, MI 48438

MATT PLACE

810 636-2570 ex 102

**GENESEE COUNTY HEALTH DEPARTMENT**  
ENVIRONMENTAL HEALTH  
630 S SAGINAW STREET  
SUITE 4  
FLINT, MI 48502-1540

GENE WOOD

810 257-3608

**GENESEE COUNTY ROAD COMMISSION**  
211 W OAKLEY STREET  
FLINT, MI 48503-3995

810 767-4920

**GENESEE COUNTY DRAIN COMMISSION**  
WATER AND WASTE SERVICES DIVISION  
4608 BEECHER ROAD  
FLINT, MI 48532

SOIL EROSION  
SEWER

810 732-1590

**STATE ELECTRICAL INSPECTOR**  
BUREAU OF CONSTRUCTION CODES  
PO BOX 30255  
LANSING, MI 48909

STEVEN BALDWIN

810 280-5520  
517 241-9313

**STATE MECHANICAL INSPECTOR**  
BUREAU OF CONSTRUCTION CODES  
PO BOX 30254  
LANSING, MI 48909

GARY BICK

989 590-8169  
517 241-9325

**STATE PLUMBING INSPECTOR**  
BUREAU OF CONSTRUCTION CODES  
PO BOX 30254  
LANSING, MI 48909

MATT HOHMAN

517 281-1108  
517 241-9330

**ADDENDUM  
CONTRACTOR'S INFORMATION**

THIS INFORMATION IS STRICTLY FOR THE CONTRACTOR,  
PLEASE DO NOT INCLUDE ANY HOMEOWNER INFORMATION.

Business Name:

---

Owners Name:

---

Address:

---

---

Contracting Companies Business Phone Number:

Business: \_\_\_\_\_ Cell: \_\_\_\_\_

After Hours Contact Person and Cell Number:

---

Superintendent Name & Cell Number:

---

Builders License Number:

---

Federal Employer ID Number or Reason for Exemption:

---

Workers Comp Insurance Carrier or Reason for Exemption:

---

MESC Employer Number or Reason for Exemption:

---

**\*\*\*WE MUST HAVE A COPY OF YOUR CURRENT BUILDERS LICENSE\*\*\***

**Electrical Permit Application**  
 Michigan Department of Licensing and Regulatory Affairs  
 Bureau of Construction Codes  
 P.O. Box 30255, Lansing, MI 48909  
 517-241-9313  
 www.michigan.gov/bcc

|   |  |
|---|--|
| Authority: 1972 PA 230<br>Penalty: Failure to provide information may result in denial of your request. | LARA is an equal opportunity employer/program. Auxiliary aids, services and other reasonable accommodations are available upon request to individuals with disabilities. |
|---|--|

**I. Project or Facility Information**

|   |      |  |        |
|---|------|--|--------|
| NAME OF OWNER/AGENT/SCHOOL/STATE DEPT.  |      | HAS A BUILDING PERMIT BEEN OBTAINED FOR THIS PROJECT?  |        |
|   |      | <input type="checkbox"/> Yes <input type="checkbox"/> No <input type="checkbox"/> Not required |        |
| STREET ADDRESS AND JOB LOCATION (Street Number and Name)  | CITY | ZIP CODE   | COUNTY |
| NAME OF CITY, VILLAGE OR TOWNSHIP IN WHICH JOB IS LOCATED   |      |  |        |
| <input type="checkbox"/> City <input type="checkbox"/> Village <input type="checkbox"/> Township    OF: |      |  |        |

**II. Applicant/Facility Contact Information**

|   |  |       |          |  |  |                 |  |
|---|--|-------|----------|--|--|-----------------|--|
| INDICATE WHO THE APPLICANT IS                                       |  | NAME  |          | STATE LICENSE NUMBER                                 |  | EXPIRATION DATE |  |
| <input type="checkbox"/> Licensee<br><input type="checkbox"/> Owner |  |       |          |  |  |                 |  |
| ADDRESS (Street Number and Name)                                    |  |       |          | STATE REGISTRATION NUMBER                            |  | EXPIRATION DATE |  |
|   |  |       |          |  |  |                 |  |
| CITY  |  | STATE | ZIP CODE | E-MAIL   |  |                 |  |
|   |  |       |          |  |  |                 |  |
| TELEPHONE NUMBER (Include Area Code)                                |  |       |          | FEDERAL EMPLOYER ID NUMBER (or reason for exemption) |  |                 |  |
|   |  |       |          |  |  |                 |  |
| WORKERS COMPENSATION INSURANCE CARRIER (or reason for exemption)    |  |       |          | UIA NUMBER (or reason for exemption)                 |  |                 |  |
|   |  |       |          |  |  |                 |  |

**III. Type of Job**

|  |                                     |   |  |                                      |
|--|-------------------------------------|---|--|--------------------------------------|
| <input type="checkbox"/> Single Family | <input type="checkbox"/> New        | <input type="checkbox"/> Service Only       | <input type="checkbox"/> Premanufactured Home Setup (State Approved) | <input type="checkbox"/> State Owned |
| <input type="checkbox"/> Other         | <input type="checkbox"/> Alteration | <input type="checkbox"/> Special Inspection | <input type="checkbox"/> Manufactured Home Setup (HUD Mobile Home)   | <input type="checkbox"/> School      |

**IV. Plan Review Information**

Plans must be submitted with an Application for Plan Examination and the appropriate deposit before a permit can be issued, except as listed below.

Plans are not required for the following:

- When the electrical system rating does not exceed 400 amps and the building is not over 3,500 square feet in area.
- Work completed by a governmental subdivision or state agency costing less than \$15,000.00.

If work being performed is described above, check box below "Plans Not Required."

What is the rating of the service or feeder in ampere? \_\_\_\_\_

What is the building size in square footage? \_\_\_\_\_

Plans are required for all other building types and shall be prepared by or under the direct supervision of an architect or engineer licensed pursuant to 1980 PA 299 and shall bear that architect's or engineer's seal and signature.

BCC Plan Review Project No. \_\_\_\_\_  Plans Not Required

**V. Applicant Signature**

Section 23a of the state construction code act of 1972, 1972 PA 230, MCL 125.1523A, prohibits a person from conspiring to circumvent the licensing requirements of this state relating to persons who are to perform work on a residential building or a residential structure. Violators of section 23a are subjected to civil fines.

|                                |      |
|--------------------------------|------|
| SIGNATURE OF LICENSEE OR OWNER | DATE |
|                                |      |

Complete Application on Back Side

**VII. Fee Schedule** - enter the number of items being installed, multiply by the unit price for total fee.

**Item #17, Mobile Home Unit Site:**

When installing a site service in a park, the permit application must include the application fee, service, the number of park sites and a final inspection. When setting a HUD mobile home in a park, a permit must include the application fee, service, feeder and a final inspection. These shall be done by a licensed electrical contractor. When setting a HUD mobile home or a premanufactured home on private property, a permit must include the application fee, service, feeder and a final inspection.

|  | Fee     | # Items | Total   |  | Fee        | # Items | Total   |
|--|---------|---------|---------|--|------------|---------|---------|
| 1. Application Fee (non-refundable)        | \$75.00 | 1       | \$75.00 | K.V.A., H. P., Wind Turbines, ***EVSE and ****PV Modules   |            |         |         |
| Service                                    |         |         |         | 19. Units up to 20 K.V.A. or H.P./Per PV Module  | \$6.00     |         |         |
| 2. Through 200 Amp.                        | \$10.00 |         |         | 20. Units 21 to 50 K.V.A. or H.P./Per PV Module  | \$10.00    |         |         |
| 3. Over 200 Amp. thru 600 Amp.             | \$15.00 |         |         | 21. Units > 50 K.V.A. or H.P. /Per PV Module   | \$12.00    |         |         |
| 4. Over 600 Amp. thru 800 Amp.             | \$20.00 |         |         | Fire Alarm Systems (not smoke detectors)   |            |         |         |
| 5. Over 800 Amp. thru 1200 Amp.            | \$25.00 |         |         | 22. Up to 10 devices   | \$50.00    |         |         |
| 6. Over 1200 Amp. (GFI only)               | \$50.00 |         |         | 23. 11 to 20 devices   | \$100.00   |         |         |
| 7. Circuits                                | \$5.00  |         |         | 24. Over 20 devices  | \$5.00 ea. |         |         |
| 8. Lighting Fixtures/Outlets - per 25      | \$6.00  |         |         | Data / Telecommunication Outlets   |            |         |         |
| 9. Dishwasher                              | \$5.00  |         |         | 31. 1 - 19 devices   | \$5.00 ea. |         |         |
| 10. Furnace - Unit Heater                  | \$5.00  |         |         | 32. 20 - 300 devices   | \$100.00   |         |         |
| 11. Electrical - Heating Units (baseboard) | \$4.00  |         |         | 33. Over 300 devices   | \$300.00   |         |         |
| 12. Power Outlets (ranges, dryers, etc.)   | \$7.00  |         |         | Energy Management Temp. Control  |            |         |         |
| Signs                                      |         |         |         | 25. Energy Retrofit - Temp. Control  | \$45.00    |         |         |
| 13. Unit                                   | \$10.00 |         |         | 34. Devices - Energy Management  | \$5.00 ea. |         |         |
| 14. Letter (each)                          | \$15.00 |         |         | 26. Conduit only or grounding only   | \$45.00    |         |         |
| 15. Neon - each 25 feet                    | \$20.00 |         |         | Inspections  |            |         |         |
| 16. Feeders-Bus Ducts, etc. - per 50'      | \$6.00  |         |         | 27. Special Insp. (pertaining to sale of building) (does not include an electrical service inspection) | \$75.00    |         |         |
| 17. Mobile Home Park Site*                 | \$6.00  |         |         | 28. Rough/Additional Inspection  | \$75.00    |         |         |
| 18. Recreational Vehicle Park Site         | \$4.00  |         |         | 29. Final Inspection   | \$75.00    | 1       | \$75.00 |
|  |         |         |         | 30. Certification Fee**  | \$30.00    |         |         |

\* See VII. Fee Schedule Item #17 above  
 \*\* Required for all school and state-owned construction projects  
 \*\*\* EVSE - Electrical Vehicle Supply Equipment  
 \*\*\*\* PV Modules - Photovoltaic  
 NOTE: Under special circumstances the bureau will assess an hourly fee for inspection services at a rate of \$75.00 per hour.

**Total Fee** (Must include the \$75 non-refundable application and \$75 final inspection fees.)

**VIII. Instructions for Completing Application**

**Make checks payable to "State of Michigan"**

**General:** Electrical work shall not be started until the application for permit has been filed with the Bureau of Construction Codes. All installations shall be in conformance with the Michigan Electrical Code. **No work shall be concealed until it has been inspected.** The telephone number for the inspector will be provided on the permit form. When ready for an inspection, call the inspector providing as much advance notice as possible. The inspector will need the job location and permit number. **Schedule permitting, an inspector will respond to an inspection request within 2 business days to schedule the inspection. The inspector will typically perform the inspection within 5 business days as his or her schedule permits.**

**Expiration of Permit:** A permit remains valid as long as work is progressing and inspections are requested and conducted. A permit shall become invalid if the authorized work is not commenced within six months after issuance of the permit or if the authorized work is suspended or abandoned for a period of six months after the time of commencing the work. **A PERMIT WILL BE CLOSED WHEN NO INSPECTIONS ARE REQUESTED AND CONDUCTED WITHIN 180 DAYS OF THE DATE OF ISSUANCE OR THE DATE OF A PREVIOUS INSPECTION. CLOSED PERMITS CANNOT BE REFUNDED. THE CHARGE TO RE-OPEN A CLOSED PERMIT IS \$75.00.**

**Where to Submit Application:** The Bureau of Construction Codes is responsible for code enforcement in units of government throughout the state which have no local program and for all state owned buildings as well as public and charter school construction where a local delegation of authority does not exist. Permit applications for state issued permits should be sent to the address on the front of this application. If you are not sure whether a state permit or a local permit is appropriate, contact our office or your local building inspector. Questions regarding state issued permits may be directed to the Office of Management Services, Permit Section at 517-241-9313. Code questions may be directed to the Electrical Division at 517-241-9320 or [bccelec@michigan.gov](mailto:bccelec@michigan.gov).

VALIDATION AREA

**Plumbing Permit Application**  
 Michigan Department of Licensing and Regulatory Affairs  
 Bureau of Construction Codes  
 P.O. Box 30255, Lansing, MI 48909  
 517-241-9313  
 www.michigan.gov/bcc

|   |  |
|---|--|
| Authority: 1972 PA 230<br>Penalty: Failure to provide information may result in denial of your request. | LARA is an equal opportunity employer/program. Auxiliary aids, services and other reasonable accommodations are available upon request to individuals with disabilities. |
|---|--|

**I. Project or Facility Information**

|   |      |  |        |
|---|------|--|--------|
| NAME OF OWNER/AGENT/SCHOOL/STATE DEPT.  |      | HAS A BUILDING PERMIT BEEN OBTAINED FOR THIS PROJECT?  |        |
|   |      | <input type="checkbox"/> Yes <input type="checkbox"/> No <input type="checkbox"/> Not required |        |
| STREET ADDRESS AND JOB LOCATION (Street Number and Name)  | CITY | ZIP CODE   | COUNTY |
| NAME OF CITY, VILLAGE OR TOWNSHIP IN WHICH JOB IS LOCATED   |      |  |        |
| <input type="checkbox"/> City <input type="checkbox"/> Village <input type="checkbox"/> Township <b>OF:</b> |      |  |        |

**II. Applicant/Facility Contact Information**

|  |                   |  |                 |
|--|-------------------|--|-----------------|
| INDICATE WHO THE APPLICANT IS  | NAME OF APPLICANT | LICENSE NUMBER                                       | EXPIRATION DATE |
| <input type="checkbox"/> Licensee <input type="checkbox"/> Owner<br><input type="checkbox"/> Water Treatment Installer |                   |  |                 |
| ADDRESS (Street Number and Name)   | CITY              | STATE  | ZIP CODE        |
| E-MAIL ADDRESS   |                   |  |                 |
| TELEPHONE NUMBER (Include Area Code)   |                   | FEDERAL EMPLOYER ID NUMBER (or reason for exemption) |                 |
| WORKERS COMPENSATION INSURANCE CARRIER (or reason for exemption)   |                   | UIA NUMBER (or reason for exemption)                 |                 |

**III. Type of Job**

|  |                                     |   |   |  |                                      |
|--|-------------------------------------|---|---|--|--------------------------------------|
| <input type="checkbox"/> Single Family | <input type="checkbox"/> New        | <input type="checkbox"/> Sewer Only         | <input type="checkbox"/> Water Service Only | <input type="checkbox"/> Premanufactured Home Setup (State Approved) | <input type="checkbox"/> State Owned |
| <input type="checkbox"/> Other         | <input type="checkbox"/> Alteration | <input type="checkbox"/> Special Inspection |   | <input type="checkbox"/> Manufactured Home Setup (HUD Mobile Home)   | <input type="checkbox"/> School      |

**IV. Plan Review Information**

Plans must be submitted with an Application for Plan Examination and the appropriate deposit before a permit can be issued, except as listed below.

Plans are not required for the following:

1. One-and two-family dwelling containing not more than 3,500 square feet of building area.
2. Alterations and repair work determined by the plumbing official to be of a minor nature.
3. Buildings with a required plumbing fixture count less than 12.
4. Work completed by a governmental subdivision or state agency costing less than \$15,000.00.

If work being performed is described above, check box below "Plans Not Required."

**Plans are required** for all other building types and shall be prepared by or under the direct supervision of an architect or engineer licensed pursuant to 1980 PA 299 and shall bear that architect's or engineer's seal and signature.

BCC Plan Review Project No. \_\_\_\_\_  Plans Not Required

**V. Applicant Signature**

Section 23a of the state construction code act of 1972, 1972 PA 230, MCL 125.1523A, prohibits a person from conspiring to circumvent the licensing requirements of this state relating to persons who are to perform work on a residential building or a residential structure. Violators of Section 23a are subjected to civil fines.

|   |      |
|---|------|
| SIGNATURE OF LICENSEE, WATER TREATMENT INSTALLER OR OWNER | DATE |
|---|------|

**VII. Fee Schedule** - enter the number of items being installed, multiply by the unit price for total fee.

**Item #2, Mobile Home Unit Site:** WHEN item is used for sewer excavations in a new park, the permit application should include the application fee, the number of unit sites and a final inspection. WHEN setting a mobile home in a park, or a mobile or modular home on private property, a permit should include the application fee, a sewer or building drain, a water service or water distribution pipe and a final inspection.

**Item #3, Fixtures, Floor Drains, Special Drains and Water Connected Appliances Include:**

|               |                        |              |                   |                |  |
|---------------|------------------------|--------------|-------------------|----------------|--|
| Water Closets | Sink (any description) | Slop Sink    | Drinking Fountain | Floor Drain    | Water Outlet or Connection to any Make-up Water Tank |
| Bathtub       | Emergency Eye Wash     | Bidet        | Condensate Drain  | Roof Drain     | Water Outlet or Connection to Heating System         |
| Lavatories    | Emergency Shower       | Cuspidor     | Washing Machine   | Grease Trap    | Water Outlet or Connection to Filters                |
| Shower Stall  | Garbage Grinder        | Dishwasher   | Acid Waste Drain  | Starch Trap    | Connection to Sprinkler System (Irrigation)          |
| Laundry Tray  | Water Outlet Cooler    | Refrigerator | Embalming Table   | Plaster Trap   | Water Connected Sterilizer                           |
| Urinal        | Ice Making Machine     |              | Bed Pan Washer    | Water Softener | Water Connected Dental Chair                         |
| Autopsy       | Water Connected Still  |              | Oil Separator     | Sand Trap      | Water Connection to Carbonated Beverage Dispensers   |

**Plus Any Other Fixture, Drain or Water Connected Appliance Not Specifically Listed**

**Item #25, Domestic Water Treatment and Filtering Equipment:** A license is not required for the installation of domestic water treatment and filtering equipment that requires modification to an existing cold water distribution supply and associated water piping in buildings if a permit is secured, required inspections performed and the installation complies with the applicable code. If the enforcing agency determines a violation exists, it shall be corrected by the responsible installer. The permit application shall include the application fee, the number of water treatment devices recorded in item #25 and the appropriate water distribution pipe (system) size fee.

|   | Fee         | # Items | Total   |  | Fee         | # Items | Total   |
|---|-------------|---------|---------|--|-------------|---------|---------|
| 1. Application Fee (non-refundable)                                   | \$75.00     | 1       | \$75.00 | Water Distributing Pipe (system)                                   |             |         |         |
| 2. Mobile Home Park Site*   | \$5.00 each |         |         | 14. 3/4" Water Distribution Pipe                                   | \$5.00      |         |         |
| 3. Fixtures, floor drains, special drains, water connected appliances | \$5.00 each |         |         | 15. 1" Water Distribution Pipe                                     | \$10.00     |         |         |
| 4. Stacks (soil, waste, vent and conductor)                           | \$3.00 each |         |         | 16. 1-1/4" Water Distribution Pipe                                 | \$15.00     |         |         |
| 5. Sewage ejectors, sumps   | \$5.00 each |         |         | 17. 1-1/2" Water Distribution Pipe                                 | \$20.00     |         |         |
| 6. Sub-soil drains  | \$5.00 each |         |         | 18. 2" Water Distribution Pipe                                     | \$25.00     |         |         |
| Water Service   |             |         |         | 19. Over 2" Water Distribution Pipe                                | \$30.00     |         |         |
| 7. Less than 2"   | \$5.00      |         |         | 20. Reduced pressure zone back-flow preventer                      | \$5.00 each |         |         |
| 8. 2" to 6"   | \$25.00     |         |         | 25. Domestic water treatment and filtering equipment <b>only**</b> | \$5.00 each |         |         |
| 9. Over 6"  | \$50.00     |         |         | 26. Medical Gas System   | \$45.00     |         |         |
| 10. Connection (bldg. drain-bldg. sewers)                             | \$5.00      |         |         | 27. Water Heater   | \$5.00      |         |         |
| Sewers (sanitary, storm or combined)                                  |             |         |         | Inspections  |             |         |         |
| 11. Less than 6"  | \$5.00      |         |         | 21. Special Insp. (pertaining to sale of building)                 | \$75.00     |         |         |
| 12. 6" and Over   | \$25.00     |         |         | 22. Rough/Additional Inspection                                    | \$75.00     |         |         |
| 13. Manholes, Catch Basins  | \$5.00 each |         |         | 23. Final Inspection   | \$75.00     | 1       | \$75.00 |
|   |             |         |         | 24. Certification Fee  | \$30.00     |         |         |

\*See VII. Fee Schedule Item #2, #3 and #25 above  
 Note: Under special circumstances the bureau will assess an hourly fee for inspection services at a rate of \$75.00 per hour.

**Total Fee** (Must include the \$75.00 non-refundable application and \$75.00 final inspection fees)

**VIII. Instructions for Completing Application**

**Make checks payable to "State of Michigan"**

**General:** Plumbing work shall not be started until the application for permit has been filed with the Bureau of Construction Codes. All installations shall be in conformance with the Michigan Plumbing Code. **No work shall be concealed until it has been inspected.** The telephone number for the inspector will be provided on the permit form. When ready for an inspection, call the inspector providing as much advance notice as possible. The inspector will need the **job location** and **permit number**. **Schedule permitting, an inspector will respond to an inspection request within 2 business days to schedule the inspection. The inspector will typically perform the inspection within 5 business days as his or her schedule permits.**

**Expiration of Permit:** A permit remains valid as long as work is progressing and inspections are requested and conducted. A permit shall become invalid if the authorized work is not commenced within 180 days after issuance of the permit or if the authorized work is suspended or abandoned for a period of 180 days after the time of commencing the work. **A PERMIT WILL BE CLOSED WHEN NO INSPECTIONS ARE REQUESTED AND CONDUCTED WITHIN 180 DAYS OF THE DATE OF ISSUANCE OR THE DATE OF A PREVIOUS INSPECTION. CLOSED PERMITS CANNOT BE REFUNDED. THE CHARGE TO RE-OPEN A CLOSED PERMIT IS \$75.00.**

**Where to Submit Application:** The Bureau of Construction Codes is responsible for code enforcement in units of government throughout the state which have no local program and for all state owned buildings as well as public and charter school construction where a local delegation of authority does not exist. Permit applications for state issued permits should be sent to the address on the front of this application. If you are not sure whether a state permit or a local permit is appropriate, contact our office or your local building inspector. Questions regarding state issued permits may be directed to the Office of Management Services, Permit Section at 517-241-9313. Code questions may be directed to the Plumbing Division at 517-241-9330 or at [bccplbg@michigan.gov](mailto:bccplbg@michigan.gov).

**VALIDATION AREA**

**Mechanical Permit Application**  
 Michigan Department of Licensing and Regulatory Affairs  
 Bureau of Construction Codes  
 P.O. Box 30255, Lansing, MI 48909  
 517-241-9313  
 www.michigan.gov/bcc

|   |  |
|---|--|
| Authority: 1972 PA 230<br>Penalty: Failure to provide information may result in denial of your request. | LARA is an equal opportunity employer/program. Auxiliary aids, services and other reasonable accommodations are available upon request to individuals with disabilities. |
|---|--|

**I. Project or Facility Information**

|   |      |  |        |  |
|---|------|--|--------|--|
| NAME OF OWNER/AGENT/SCHOOL/STATE DEPT.  |      | HAS A BUILDING PERMIT BEEN OBTAINED FOR THIS PROJECT?  |        |  |
|   |      | <input type="checkbox"/> Yes <input type="checkbox"/> No <input type="checkbox"/> Not required |        |  |
| STREET ADDRESS AND JOB LOCATION (Street Number and Name)  | CITY | ZIP CODE   | COUNTY |  |
| NAME OF CITY, VILLAGE OR TOWNSHIP IN WHICH JOB IS LOCATED   |      |  |        |  |
| <input type="checkbox"/> City <input type="checkbox"/> Village <input type="checkbox"/> Township <b>OF:</b> |      |  |        |  |

**II. Applicant/Facility Contact Information**

|   |                        |                                      |                |                 |
|---|------------------------|--------------------------------------|----------------|-----------------|
| INDICATE APPLICANT<br><input type="checkbox"/> Licensee<br><input type="checkbox"/> Owner | NAME OF OWNER/LICENSEE | COMPANY NAME                         | LICENSE NUMBER | EXPIRATION DATE |
| ADDRESS (Street Number and Name)  |                        | CITY                                 | STATE          | ZIP CODE        |
| TELEPHONE NUMBER (Include Area Code)  |                        | E-MAIL ADDRESS                       |                |                 |
| FEDERAL EMPLOYER ID NUMBER (or reason for exemption)                                      |                        |                                      |                |                 |
| WORKERS COMPENSATION INSURANCE CARRIER (or reason for exemption)                          |                        | UIA NUMBER (or reason for exemption) |                |                 |

**III. Type of Job**

|  |                                     |  |                                      |
|--|-------------------------------------|--|--------------------------------------|
| <input type="checkbox"/> Single Family                             | <input type="checkbox"/> New        | <input type="checkbox"/> Special Inspection                          | <input type="checkbox"/> State Owned |
| <input type="checkbox"/> Other                                     | <input type="checkbox"/> Alteration | <input type="checkbox"/> Premanufactured Home Setup (State Approved) | <input type="checkbox"/> School      |
| <input type="checkbox"/> Manufactured Home Setup (HUD Mobile Home) |                                     |  |                                      |

**IV. Plan Review Information**

Plans must be submitted with an Application for Plan Examination and the appropriate deposit before a permit can be issued, except as listed below.

Plans are not required for the following:

- One-and two-family dwellings when the total building heating/cooling system input rating is 375,000 Btu's or less.
- Alterations and repair work determined by the mechanical official to be of a minor nature.
- Business, mercantile, and storage buildings having HVAC equipment only, with one fire area and not more than 3,500 square feet.
- Work completed by a governmental subdivision or state agency costing less than \$15,000.00.

If work being performed is described above, check box below "Plans Not Required."

What is the building size in square footage? \_\_\_\_\_  
 What is the input rating of the heating system in this building? \_\_\_\_\_

Plans are required for all other building types and shall be prepared by or under the direct supervision of an architect or engineer licensed pursuant to 1980 PA 299 and shall bear that architect's or engineer's seal and signature.

BCC Plan Review Project No. \_\_\_\_\_  Plans Not Required

**V. Applicant Signature**

Section 23a of the state construction code act of 1972, 1972 PA 230, MCL 125.1523A, prohibits a person from conspiring to circumvent the licensing requirements of this state relating to persons who are to perform work on a residential building or a residential structure. Violators of section 23a are subjected to civil fines.

|                                  |      |
|----------------------------------|------|
| SIGNATURE OF CONTRACTOR OR OWNER | DATE |
|                                  |      |

VII. Fee Schedule

**Item #2, Residential Heating System:** This item is used for the installation of a heating system in a new residential structure. Items #10 Gas Piping and #18 Duct need not be added. Replacement systems should be itemized.

|   | Fee       | # of Items | Total   |
|---|-----------|------------|---------|
| 1. Application Fee (non-refundable)                                     | \$75.00   | 1          | \$75.00 |
| 2. Residential Heating System (includes duct & pipe) New Building Only* | \$50.00   |            |         |
| 3. Gas/Oil Burning Equipment (furnance, roof top units, generators)     | \$30.00   |            |         |
| 4. Boiler   | \$30.00   |            |         |
| 5. Water Heater (gas piping & venting-direct replacement only)          | \$5.00    |            |         |
| 6. Damper (control, back-draft, barometric or fire/smoke)               | \$5.00    |            |         |
| 7. Solid Fuel Equipment (includes chimney)                              | \$30.00   |            |         |
| 8. Chimney, factory built (installed separately), B Vent, PVC Venting   | \$25.00   |            |         |
| 37. Gas Burning Fireplace   | \$30.00   |            |         |
| 9. Solar; set of 3 panels-fluid transfer (includes piping)              | \$20.00   |            |         |
| 10. Gas Piping; each opening-new install (residential)                  | \$5.00    |            |         |
| 11. Air Conditioning (incl. split systems) RTU-Cooling Only             | \$30.00   |            |         |
| 12. Heat Pumps (split systems) or Geothermal (complete residential)     | \$30.00   |            |         |
| 13. Dryer, Bath & Kitchen Exhaust (residential ducting not included)    | \$5.00    |            |         |
| 16. Humidifiers/Air Cleaners  | \$10.00   |            |         |
| <b>Tanks</b>  |           |            |         |
| 14. Aboveground (other than L.P.)                                       | \$20.00   |            |         |
| 38. Aboveground Connection  | \$20.00   |            |         |
| 15. Underground (other than L.P.)                                       | \$25.00   |            |         |
| 39. Underground Connection  | \$25.00   |            |         |
| <b>Piping (ALL piping-minimum fee \$25.00)</b>                          |           |            |         |
| 17. Fuel Gas Piping   | \$.05 /ft |            |         |
| 40. Process Piping  | \$.05 /ft |            |         |
| 41. Hydronic Piping   | \$.05 /ft |            |         |
| 42. Refrigeration Piping  | \$.05 /ft |            |         |
| 46. Commercial Air Conditioning Piping                                  | \$.05 /ft |            |         |

|   | Fee          | # of Items | Total   |
|---|--------------|------------|---------|
| 43. Exhausters (commercial)   | \$15.00      |            |         |
| 18. Duct - minimim fee \$25.00  | \$.10 /ft    |            |         |
| 19. Heat Pumps; Commercial (pipe not included)                        | \$20.00      |            |         |
| <b>Air Handlers/Heat Wheels</b>                                       |              |            |         |
| 20. Under 10,000 CFM  | \$20.00      |            |         |
| 21. Over 10,000 CFM   | \$60.00      |            |         |
| 22. Commercial Hoods  | \$15.00      |            |         |
| 23. Heat Recovery Units   | \$10.00      |            |         |
| 24. V.A.V. Boxes (all variable volume or zone damper equipment)       | \$10.00      |            |         |
| 25. Unit Ventilators/PTAC Units                                       | \$10.00      |            |         |
| 26. Unit Heaters (terminal units)                                     | \$15.00      |            |         |
| 27. Fire Suppression/Protection (includes piping)-minimum fee \$20.00 | \$.75 / head |            |         |
| 28. Coils (Heat/Cool)   | \$30.00      |            |         |
| 29. Refrigeration (split system)                                      | \$30.00      |            |         |
| <b>Chiller/Cooling Towers</b>   |              |            |         |
| 30. Chiller-Refrigeration   | \$30.00      |            |         |
| 44. Chiller-Air Conditioning  | \$30.00      |            |         |
| 31. Cooling Towers-Refrigeration                                      | \$30.00      |            |         |
| 45. Cooling Towers-Air Conditioning                                   | \$30.00      |            |         |
| 32. Compressor/Condenser  | \$30.00      |            |         |
| <b>Inspections</b>  |              |            |         |
| 33. Special Insp. (pertaining to sale of bldg.)                       | \$75.00      |            |         |
| 34. Rough/Additional Inspection                                       | \$75.00      |            |         |
| 35. Final Inspection  | \$75.00      | 1          | \$75.00 |
| 36. Certification Fee   | \$30.00      |            |         |

\*See VII. Fee Schedule Item #2 above  
 NOTE: Under special circumstances the bureau will assess an hourly fee for inspection services at a rate of \$75.00 per hour.

**Total Fee (Must include the \$75 non-refundable application and \$75 final inspection fees)**

**Make checks payable to "State of Michigan"**

VIII. Instructions for Completing Application

**General:** Mechanical work shall not be started until the application for permit has been filed with the Bureau of Construction Codes. All installations shall be in conformance with the Michigan Mechanical Code. No work shall be concealed until it has been inspected. The telephone number for the inspector will be provided on the permit form. When ready for an inspection, call the inspector providing as much advance notice as possible. The inspector will need the job location and permit number. *Schedule permitting, an inspector will respond to an inspection request within 2 business days to schedule the inspection. The inspector will typically perform the inspection within 5 business days as his or her schedule permits.*

**Expiration of Permit:** A permit remains valid as long as work is progressing and inspections are requested and conducted. A permit shall become invalid if the authorized work is not commenced within 180 days after issuance of the permit or if the authorized work is suspended or abandoned for a period of 180 days after the time of commencing the work. **A PERMIT WILL BE CLOSED WHEN NO INSPECTIONS ARE REQUESTED AND CONDUCTED WITHIN 180 DAYS OF THE DATE OF ISSUANCE OR THE DATE OF A PREVIOUS INSPECTION. CLOSED PERMITS CANNOT BE REFUNDED. THE CHARGE TO RE-OPEN A CLOSED PERMIT IS \$75.00.**

**Where to Submit Application:** The Bureau of Construction Codes is responsible for code enforcement in units of government throughout the state which have no local program and for all state owned buildings as well as public and charter school construction where a local delegation of authority does not exist. Permit applications for state issued permits should be sent to the address on the front of this application. If you are not sure whether a state permit or a local permit is appropriate, contact our office or your local building inspector. Questions regarding state issued permits may be directed to the Office of Management Services, Permit Section at 517-241-9313. Code questions may be directed to the Mechanical Division at 517-241-9325 or by email at [bccmech@michigan.gov](mailto:bccmech@michigan.gov).

Validation Area





G-4610 Beecher Road Flint, MI 48532  
 Phone (810) 732-7870 Fax (810) 732-9773  
[www.qcdcwws.com](http://www.qcdcwws.com)

**OFFICE USE ONLY**

|                 |
|-----------------|
| Permit Number   |
| Date Issued     |
| Expiration Date |
| File Number     |

**\*\*This does not constitute as the permit.**

**RESIDENTIAL SOIL EROSION & SEDIMENTATION CONTROL PERMIT APPLICATION**

1. **APPLICANT** (The Designated Agent shall complete this section unless the work is being performed by the Landowner\*)

|   |        |       |        |
|---|--------|-------|--------|
| <input type="checkbox"/> Landowner<br><input type="checkbox"/> Designated Agent |        | NAME: | EMAIL: |
| ADDRESS:  |        |       |        |
| CITY:   | STATE: | ZIP:  | PHONE: |

2. **LOCATION**

|              |                 |  |                   |
|--------------|-----------------|--|-------------------|
| SECTION      | Township - T__N | <input type="checkbox"/> CITY<br><input type="checkbox"/> TOWNSHIP<br><input type="checkbox"/> VILLAGE | PROPERTY TAX ID # |
|              | Range - R__E    |  |                   |
| SUBDIVISION: | LOT #           | STREET ADDRESS:  |                   |

3. **PROPOSED EARTH CHANGE**

|  |                       |  |  |
|--|-----------------------|--|--|
| Project Type: Residential <input type="checkbox"/> Industrial <input type="checkbox"/> Multi-Family <input type="checkbox"/> Land Balancing <input type="checkbox"/> Commercial <input type="checkbox"/> |                       |  |  |
| Describe Project   |                       | Size of Earth Change (Acres, Linear feet or square feet) |  |
| Name of <b>and</b> distance to nearest Lake, Stream, or Drain  | Date Project to start | Date Project to be complete                              |  |

4. **SOIL EROSION AND SEDIMENTATION CONTROL PLAN** (Refer to Rule 323.1703 of Part 91)

|  |   |         |
|--|---|---------|
| <b>Note: Two complete set of plans must be provided prior to issuance of a permit. Submit one copy for review.</b> | Estimated Cost of Erosion and Sedimentation Control |         |
|  | Plan Preparer's Name                                | Phone # |

5. **PARTIES RESPONSIBLE FOR EARTH CHANGE**

|   |       |         |              |       |
|---|-------|---------|--------------|-------|
| Name of Landowner (if not provided in Box. 1 above)       |       | Address |              |       |
| Email:  |       |         |              |       |
| City  | State | Zip     | Phone #      |       |
| Name of Individual "On Site" Responsible for Earth Change |       |         | Company Name |       |
| Email:  |       |         |              |       |
| Address   | City  | State   | Zip          | Phone |

|  |  |  |  |  |
|--|--|--|--|--|
|  |  |  |  |  |
|--|--|--|--|--|

**6. PERFORMANCE DEPOSIT (If required by the permitting agency)**

|                         |      |       |     |       |
|-------------------------|------|-------|-----|-------|
| Amount Required \$:     |      |       |     |       |
| Name of Surety Company: |      |       |     |       |
| Address                 | City | State | Zip | Phone |

Note: If an individual homeowner/landowner (owning not more than 2 lots) is undertaking an earth change on their residential property or single family lot, a security may be required at the discretion of GCDC-WWS. If no security is required, the homeowner/landowner shall provide written authorization allowing GCDC-WWS to enter onto their property and perform any necessary work to gain Part 91 compliance in the event the site is in noncompliance. The homeowner/landowner must also acknowledge in writing that a lien will be placed on their property for the cost of the work done by GCDC-WWS.

When a contractor is performing the work, a security is required in the amount of \$3,000.00 per acre/or part of, shall be posted and retained until such time as the SESC permit is considered closed by GCDC-WWS.

**7. NOTICE TO APPLICANT**

I understand that if a soil erosion and sedimentation control permit OR a waiver of a soil erosion and sedimentation control permit is issued, the above-mentioned property is not exempt from enforcement procedures under Part 91, of Act No. 451 of the Public Acts of 1994, as amended, being MCL § 324.32501 *et. seq.*

I hereby acknowledge that if a soil erosion and sedimentation control permit OR a waiver of a soil erosion and sedimentation control permit is issued, I hereby voluntarily grant the employees of the Genesee County Drain Commissioner's Office, Division of Water and Waste Services, or their designated agents permission to enter onto my property as set forth herein to ensure that the project conforms to the reason stated above as to why the proposed project qualifies for a soil erosion and sedimentation permit waiver. I further understand that if I revoke my consent for the employees of the Genesee County Drain Commissioner's Office, Division of Water and Waste Services, or their designated agents to enter onto the property set forth herein, the permit waiver is automatically revoked, I will need to resubmit a new soil erosion and sedimentation permit application or waiver certification, and I must cease all earth moving activities on the property.

I further understand that if I continue to perform earth moving activities on the property after revoking my consent for the employees of the Genesee County Drain Commissioner's Office, Division of Water and Waste Services, or their designated agents to enter onto the property set forth herein, I may be subject to one or more of the enforcement procedures set forth in Part 91 of Act No. 451 of the Public Acts of 1994, as amended, and the administrative rules promulgated thereunder, including, but not limited to, being issued a civil infraction citation, having an injunction issued to prevent any further earth moving activities on the aforementioned property, the right of the Genesee County Drain Commissioner's Office, Division of Water and Waste Services or its agents to enter onto my property to install soil erosion and sedimentation control procedures and lien the property for all costs associated with installing the soil erosion and sedimentation control procedures, and/or the forfeiture of any security submitted in the amount required to bring the property into compliance with Part 91 of Act No. 451 of the Public Acts of 1994, as amended.

I hereby acknowledge that the information contained herein is truthful and accurate to the best of my knowledge. I understand that if I knowingly make any false statement in this application it may result in a civil fine of not more than \$10,000.00 per day for each violation.

|   |            |      |
|---|------------|------|
| I (we) affirm that the above information is accurate and that I (we) will conduct the above-described earth change in accordance with Part 91, Soil Erosion and Sedimentation Control, of the Natural Resource and Environmental Protection Act, 1994 PA 451, as amended, applicable local ordinances, and the documents accompanying this application. |            |      |
| Landowner's Signature   | Print Name | Date |
| Designated Agent's Signature*   | Print Name | Date |

- Designated agent must have a written statement from landowner authorizing him/her to secure a permit in the landowner's name.

**OFFICE USE ONLY**

|  |
|--|
|  |
|  |
|  |
|  |
|  |
|  |
|  |
|  |

**Genesee County Drain Commissioner Division of Water and Waste Services**  
**Residential Soil Erosion and Sedimentation Control Plan Submittal Checklist**

**All SESC plans submitted to this office shall at a minimum be accompanied by the following information.**

1. \_\_\_\_ Soil Erosion and Sedimentation Control application review fee. Fee schedule is listed below. Checks shall be payable to the Genesee County Drain Commissioner's Office.  
Application Review Fee  
Single Family Residential:           \$ 35.00
  
2. \_\_\_\_ Legal description, tax I.D. number and/or survey of site.
  
3. \_\_\_\_ A SESC site plan (scale of not more than 1"=200' on 24"x36" sheets) of the property with the items below clearly labeled :(Residential can be submitted on letter or legal paper)
  - A. \_\_\_\_ Name and address of Applicant. Name and address of landowner.
  
  - B. \_\_\_\_ Project Name, location, proximity to waters of the State (lake, stream, drain, wetlands) and (the 100 year floodplain contour for those waters for commercial applications only).
  
  - C. \_\_\_\_ Location map, NORTH arrow and drawing scale.
  
  - D. \_\_\_\_ Limits of earth change delineated and clearly labeled.
  
  - E. \_\_\_\_ Existing and proposed contours. If unchanged so state.
  
  - F. \_\_\_\_ Existing and proposed on-site and off-site (within drainage area of earth change) drainage and dewatering facilities including temporary dewatering shall be clearly labeled and identified.
  
  - G. \_\_\_\_ Predominant land features shall be labeled on the drawings. (Buildings, rivers, streams, etc.)
  
  - H. \_\_\_\_ Existing on-site vegetation (type and location).
  
  - I. \_\_\_\_ Soil stock pile locations.
  
  - J. \_\_\_\_ Description of installation and location of all temporary and permanent erosion control measures, with measures clearly drafted and labeled with the (Michigan Unified Keying System and GCDC-WWS Specifications for commercial applications only).
  
  - K. \_\_\_\_ A program proposal for the continued maintenance of all permanent soil erosion and sediment control measures that remain after project completion.

L. \_\_\_ Person responsible for continued maintenance once permit is closed

Name: \_\_\_\_\_  
Address: \_\_\_\_\_  
Phone #: \_\_\_\_\_  
Email address: \_\_\_\_\_

4. \_\_\_ A topographic map with the affected area clearly labeled.
5. \_\_\_ Existing soils information, with project area clearly labeled. (Soils Map)
6. \_\_\_ A completed Soil Erosion and Sedimentation Control application.
7. \_\_\_ A completed construction and maintenance schedule including a plan for permanent stabilization.
8. \_\_\_ A copy of any submitted EGLE permit applications (as applicable) required for completing earthwork within the boundaries of waters of the state.
9. \_\_\_ A copy of sedimentation basin capacity calculation for sites that require sedimentation basins. (This may not be required for Residential Properties)

**I hereby certify that the above information has been provided with the submitted plans.**

Name of Party Preparing Checklist: \_\_\_\_\_

E-mail address of Party Preparing Checklist: \_\_\_\_\_

Signature: \_\_\_\_\_ Date: \_\_\_\_\_

**Note: It is necessary to submit only one set of plans for review**

# SESC CONSTRUCTION AND MAINTENANCE SCHEDULE

Project Name: \_\_\_\_\_  
 Anticipated Start Date: \_\_\_\_\_  
 Anticipated End Date: \_\_\_\_\_

## Construction Schedule

| Construction Sequence   | Jan | Feb | Mar | Apr | May | Jun | Jul | Aug | Sep | Oct | Nov | Dec | Notes |
|-------------------------|-----|-----|-----|-----|-----|-----|-----|-----|-----|-----|-----|-----|-------|
| Temporary SESC Measures |     |     |     |     |     |     |     |     |     |     |     |     |       |
| Building Demolition     |     |     |     |     |     |     |     |     |     |     |     |     |       |
| Strip and Stockpile     |     |     |     |     |     |     |     |     |     |     |     |     |       |
| Rough Grading           |     |     |     |     |     |     |     |     |     |     |     |     |       |
| Underground Utilities   |     |     |     |     |     |     |     |     |     |     |     |     |       |
| Road Installation       |     |     |     |     |     |     |     |     |     |     |     |     |       |
| Building Construction   |     |     |     |     |     |     |     |     |     |     |     |     |       |
| Permanent SESC Measures |     |     |     |     |     |     |     |     |     |     |     |     |       |
| Final Grade             |     |     |     |     |     |     |     |     |     |     |     |     |       |
| Landscaping             |     |     |     |     |     |     |     |     |     |     |     |     |       |

## Maintenance Schedule

| Maintenance Sequence      | Jan | Feb | Mar | Apr | May | Jun | Jul | Aug | Sep | Oct | Nov | Dec | Notes |
|---------------------------|-----|-----|-----|-----|-----|-----|-----|-----|-----|-----|-----|-----|-------|
| Street Sweeping           |     |     |     |     |     |     |     |     |     |     |     |     |       |
| Silt Fencing              |     |     |     |     |     |     |     |     |     |     |     |     |       |
| Maintain Buffer Strips    |     |     |     |     |     |     |     |     |     |     |     |     |       |
| Inlet Structures          |     |     |     |     |     |     |     |     |     |     |     |     |       |
| Seeding and Mulch         |     |     |     |     |     |     |     |     |     |     |     |     |       |
| Sediment Basins           |     |     |     |     |     |     |     |     |     |     |     |     |       |
| Rip-Rap                   |     |     |     |     |     |     |     |     |     |     |     |     |       |
| Remove Temporary Measures |     |     |     |     |     |     |     |     |     |     |     |     |       |

## Seeding and Planting Schedule

**Temporary:** (Refer to Tables 4 & 6 in MDEQ "Guidelines for Vegetative Erosion control" included with this packet)

| Area on Plan | Mix # | Common Name | Natural Drainage Class Suitability | Suitable Uses | Rate lb/acre |
|--------------|-------|-------------|------------------------------------|---------------|--------------|
|              |       |             |                                    |               |              |
|              |       |             |                                    |               |              |
|              |       |             |                                    |               |              |

**Permanent:** (Refer to Tables 4 & 6 in MDEQ "Guidelines for Vegetative Erosion control" included with this packet)

| Area on Plan | Mix # | Common Name | Natural Drainage Class Suitability | Suitable Uses | Rate lb/acre |
|--------------|-------|-------------|------------------------------------|---------------|--------------|
|              |       |             |                                    |               |              |
|              |       |             |                                    |               |              |
|              |       |             |                                    |               |              |

**Trees and Shrubs:** (Refer to Table 7 in MDEQ "Guidelines for Vegetative Erosion control" included with this packet)

| Area on Plan | Quantity | Common Name | Scientific Name | Drainage Class | Notes |
|--------------|----------|-------------|-----------------|----------------|-------|
|              |          |             |                 |                |       |
|              |          |             |                 |                |       |
|              |          |             |                 |                |       |

# EXAMPLE SINGLE FAMILY HOME SITE PLAN MINIMUM GUIDE FOR RESIDENTIAL SESC APPLICATION

HOUSE PLOT PLAN FOR:  
JOE SMITH  
1111 MAIN STREET  
FLINT, MI 48503

LOT 74 OF "MORIDAN ACRES" AS  
RECORDED IN LIBER 55, PAGES  
222-225

NOTE: THIS EXACT  
EXAMPLE PAGE IS NOT  
TO BE INCLUDED IN  
THE PERMIT.



1" = 30'

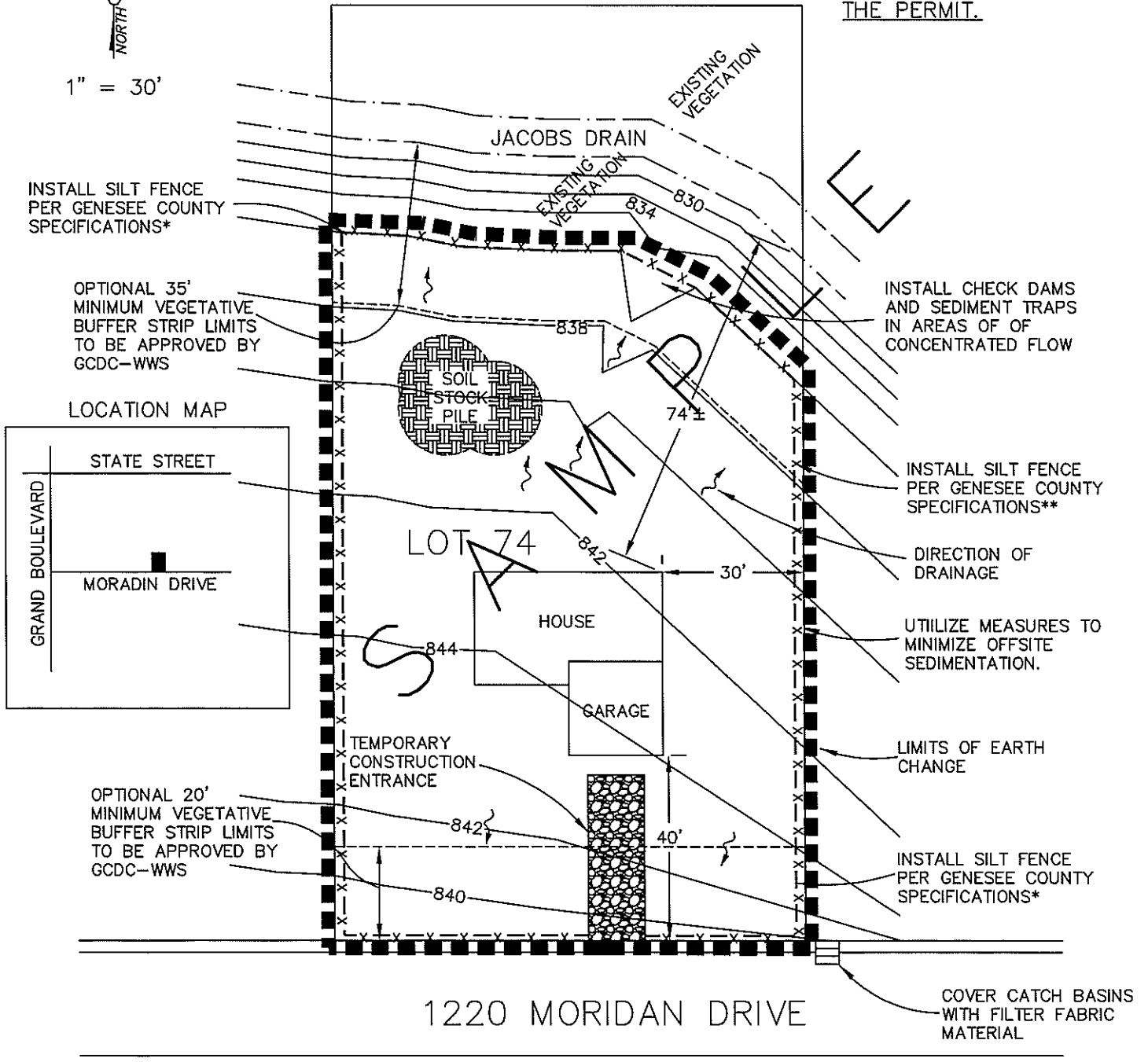

\* SILT FENCE IS NOT NECESSARY SO LONG AS A MINIMUM THICK 20' VEGETATIVE BUFFER STRIP IS MAINTAINED DURING CONSTRUCTION.

\*\* SILT FENCE IS NOT NECESSARY SO LONG AS A MINIMUM THICK 35' VEGETATIVE BUFFER STRIP IS MAINTAINED ALONG ALL WATERS OF THE STATE DURING CONSTRUCTION.

NOTE: THE WIDTH OF THE VEGETATIVE BUFFER STRIPS WILL BE MODIFIED PER ON-SITE CONDITIONS AND BE APPROVED BY GCDC-WWS.

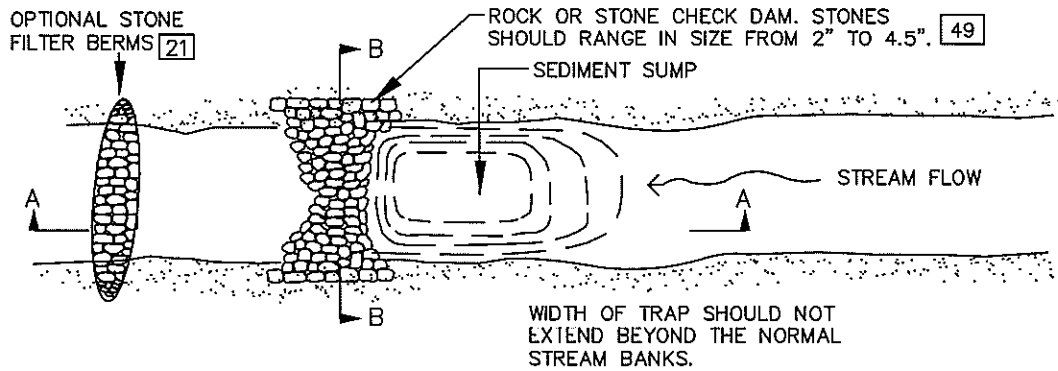

PLAN VIEW

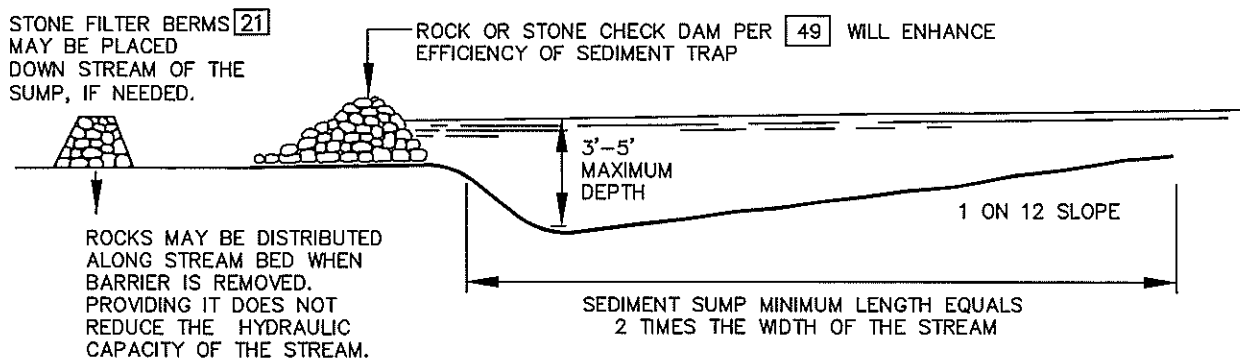

SECTION A - A

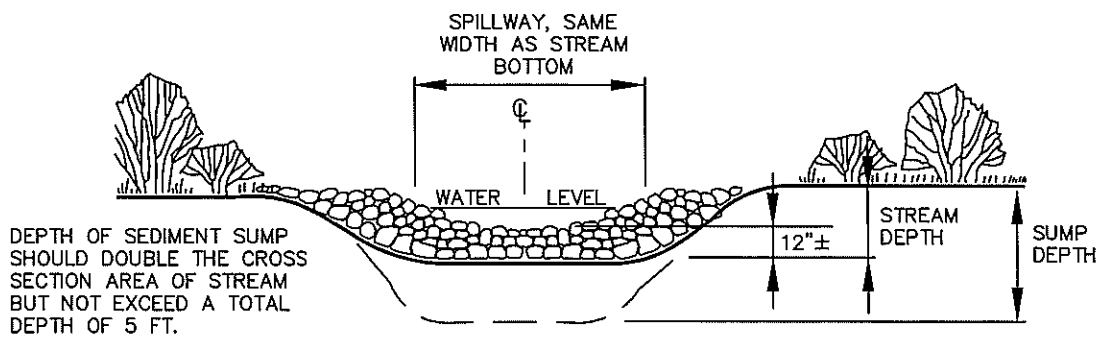

SECTION B - B

APPLICATION

1. FLOWING STREAMS.

DESIGN

1. TRAP DESIGN FOR APPROXIMATELY 170 FT<sup>3</sup> OF SEDIMENT.
2. REMOVED SEDIMENT AND RESTORE ORIGINAL CAPACITY WHEN SUMP IS 50% FULL.
3. STONE SHALL BE MAINTAINED AND REPAIRED WHEN DAMAGE OR DISPLACED.
4. WARNING! THIS DEVICE MAY CAUSE FLOODING OF ADJACENT PROPERTY.



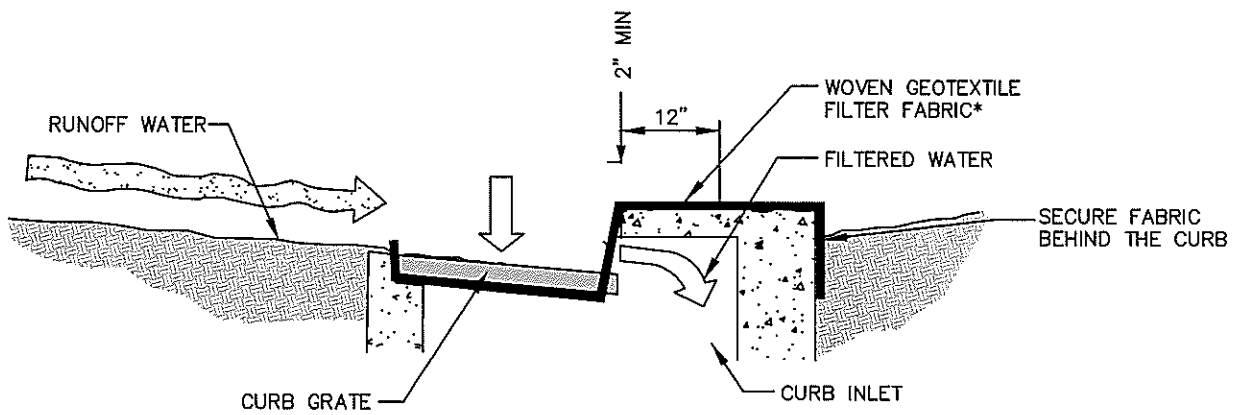
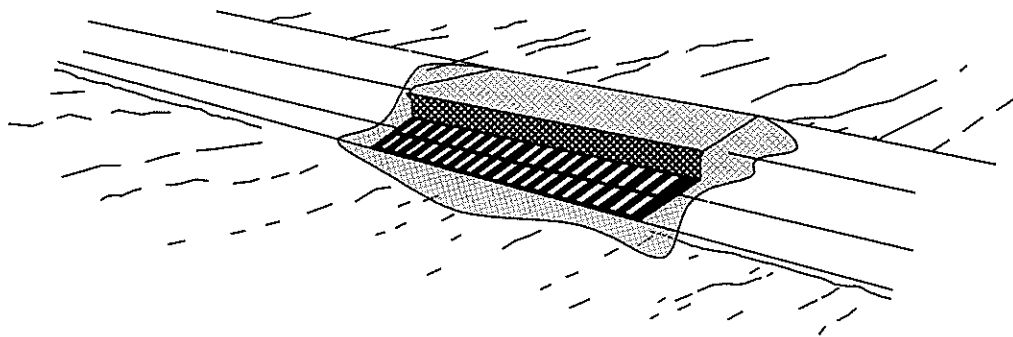

APPLICATION

1. INLETS AT CURB OPENINGS.

\* NOTE \*

DO NOT USE SILT FENCE IN LIEU OF FILTER FABRIC FOR THIS APPLICATION.

DESIGN

1. FILTER BAGS MAY BE PLACED IN THE CATCH BASIN AS AN ALTERNATE.
2. WARNING! THIS DEVICE MAY CAUSE FLOODING OF ADJACENT PROPERTIES.
3. SERVICE CLEAN AND REPAIR AFTER EACH STORM EVENT.

FABRIC FILTER  
CURB INLET PROTECTION

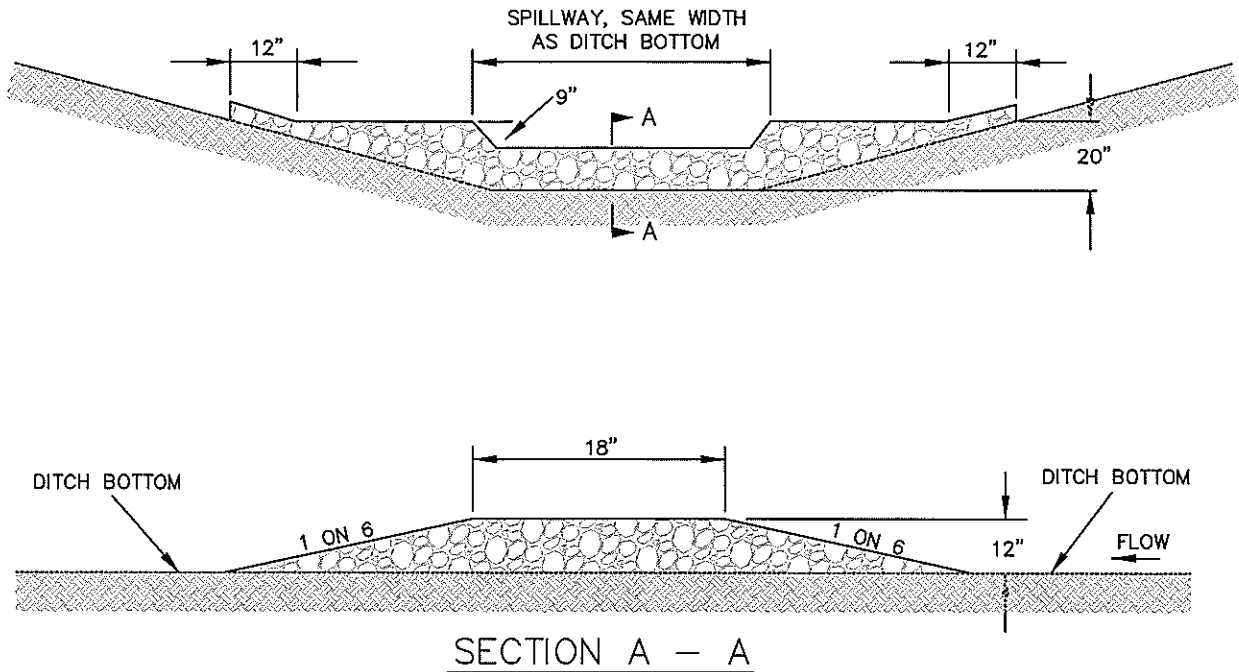

#### APPLICATION

1. ACROSS DITCH LINES AND LOW CONCENTRATED FLOW AREAS.

#### DESIGN

1. CHECK DAM STONES:  
2" TO 4" SIZE FOR DITCH GRADE LESS THAN 2%.  
3" TO 8" SIZE FOR DITCH GRADES 2% OR GREATER.
2. APPROXIMATELY 90% OF STONE SIZE SHALL BE BETWEEN THE RANGES INDICATED. NO STONES GREATER THAN 8" SHALL BE ALLOWED.
3. SEDIMENT TRAPS MAY BE INSTALLED IMMEDIATELY UP SLOPE TO INCREASE ABILITY TO COLLECT SEDIMENT.
4. IF MULTIPLE CHECK DAMS ARE USED, THE GENERAL GUIDE TO SPACING IS THAT THE CREST OF THE DOWN SLOPE CHECK DAM SHOULD EQUAL THE ELEVATION OF THE TOE OF THE UP SLOPE CHECK DAM.

#### DESIGN (CONT)

5. CHECK DAMS SHALL BE REMOVED IN THEIR ENTIRETY WHEN THE SOIL IS ADEQUATELY STABILIZED. ANY DAMAGE CAUSED DURING REMOVAL MUST BE REPAIRED. IF DIRECTED BY THE ENGINEER/OWNER, CHECK DAMS MAY BE SPREAD OUT ON THE DITCH LOCATION PROVIDING THAT THE DITCH BOTTOM ELEVATION IS NOT INCREASED BY MORE THAN 6".
6. STONE SHALL BE MONITORED AND REPAIRED WHEN DAMAGED OR DISPLACED.
7. ALTERNATE: A MANUFACTURED BERM CAN BE INSTALLED IF APPROVED BY WWS. SPACING TO BE PER MANUFACTURER'S RECOMMENDATION.
8. WARNING THIS DEVICE MAY CAUSE FLOODING OF ADJACENT PROPERTY.

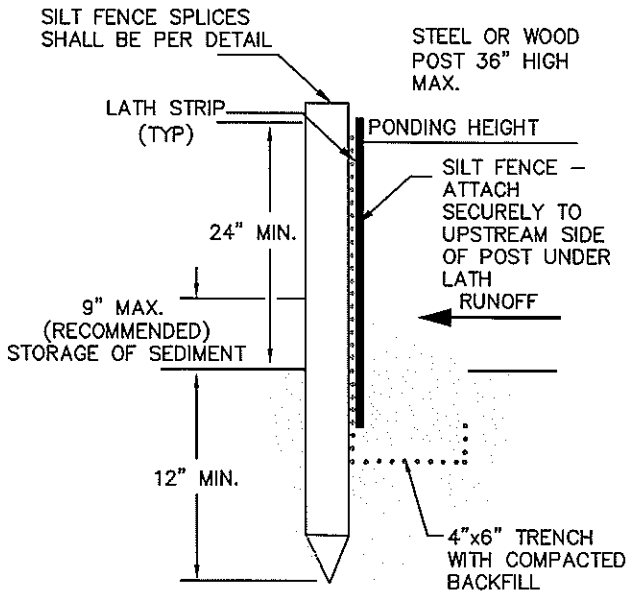
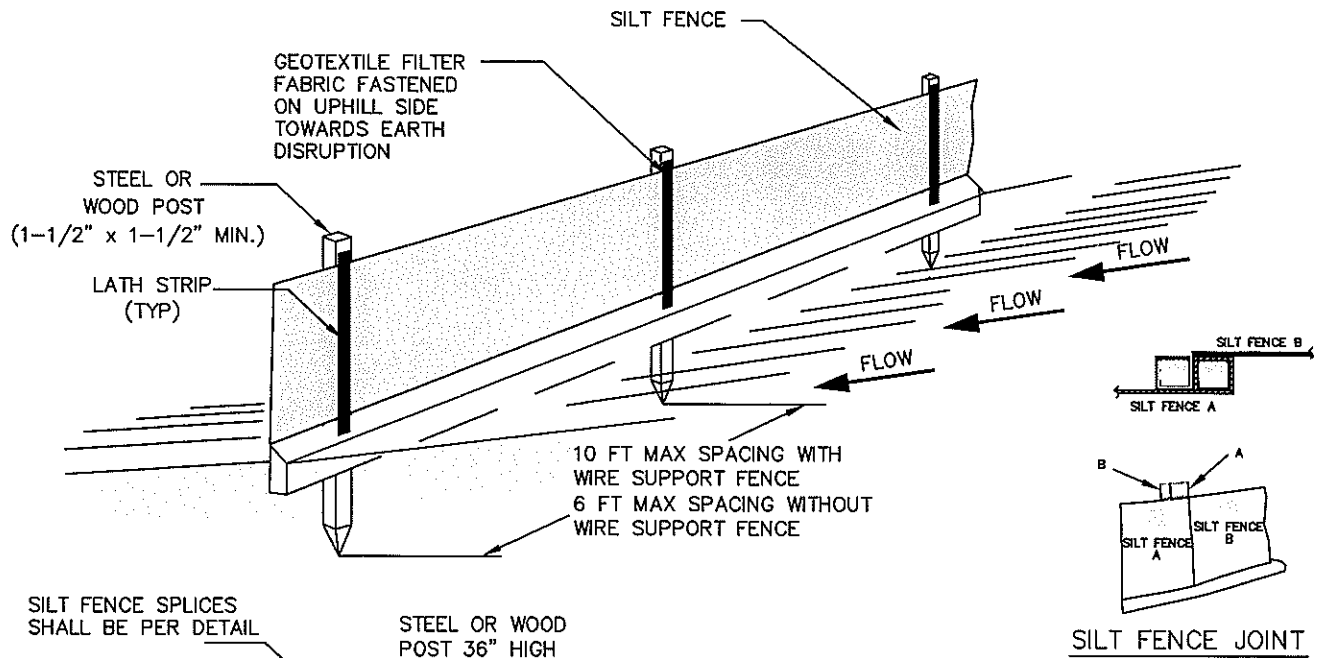

STANDARD DETAIL  
TRENCH WITH NATIVE BACKFILL

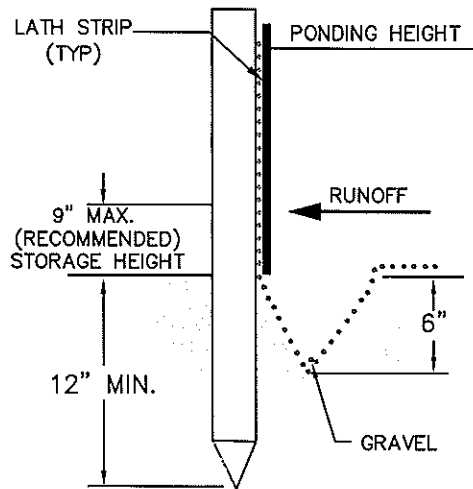

ALTERNATE DETAIL  
TRENCH WITH GRAVEL

APPLICATIONS

1. INSTALLED TO REDUCE SEDIMENT LADEN SURFACE RUNOFF FROM LEAVING THE PROPERTY OF A CONSTRUCTION SITE INVOLVING DISTURBED EARTH.
2. DIVERSIONARY STRUCTURE.

DESIGN

1. INSTALL AROUND THE BASE OF SOIL STOCKPILES.
2. UTILIZE FOR SHEET FLOW ONLY.

DESIGN (CONT)

3. INSTALL ON DOWN STREAM SIDE OF CONSTRUCTION.
4. SILT FENCE SHALL BE PLACED ON SLOPE CONTOURS TO MAXIMIZE PONDING EFFICIENCY.
5. IF POSSIBLE LOCATE FENCE 10-FT. FROM TOP OF SLOPE, WETLAND OR WATER BODY.
6. JOIN SECTIONS OF SILT FENCE BY WRAPPING THE ENDS TOGETHER.

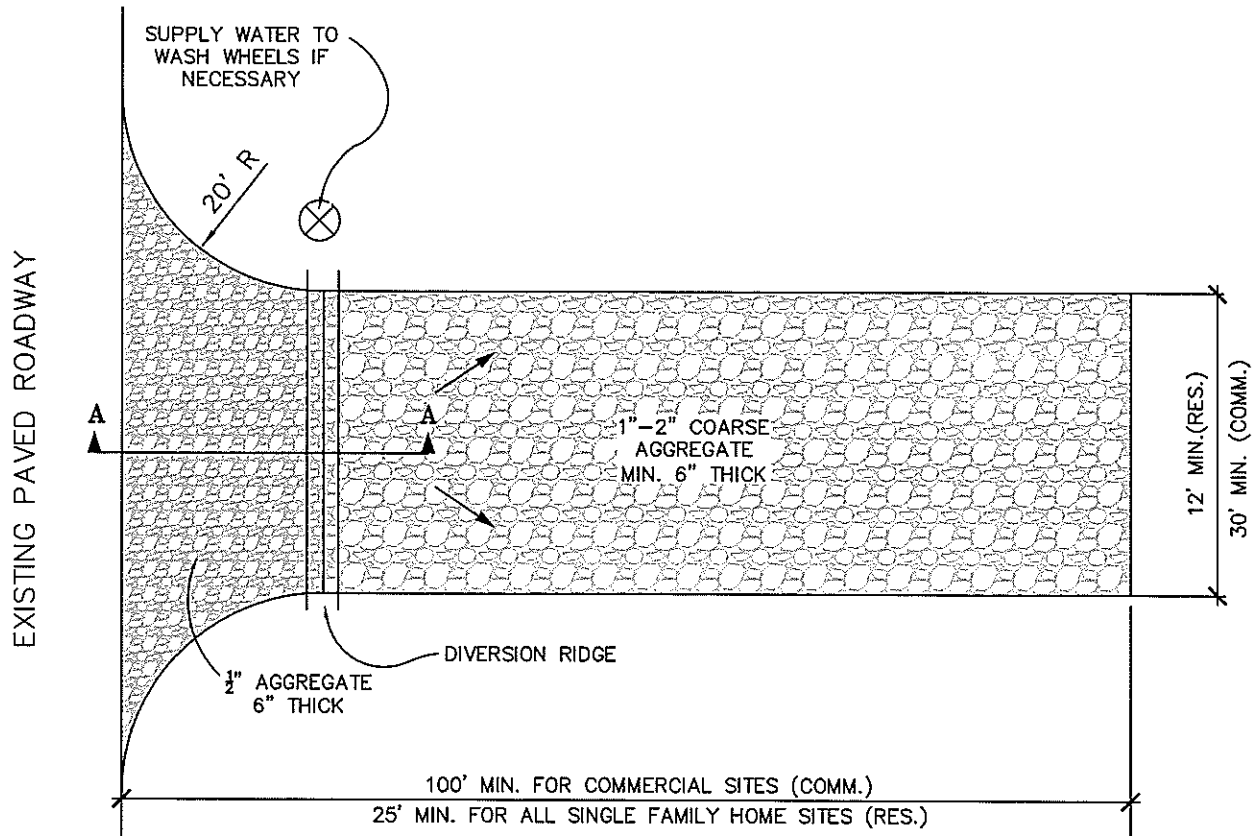

PLAN

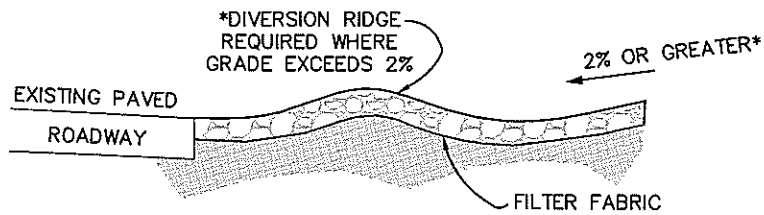

SECTION A - A

APPLICATIONS

1. ASSISTS IN REMOVING SOIL FROM THE TIRES OF CONSTRUCTION EQUIPMENT/VEHICLES WHEN EXITING THE CONSTRUCTION SITE. THIS REDUCES TRACKING EXCESSIVE SEDIMENT/SOIL ONTO THE ADJACENT ROAD.

DESIGN

1. THE ENTRANCE SHALL BE MAINTAINED IN A CONDITION THAT WILL PREVENT TRACKING OR FLOWING OF SEDIMENT ONTO PUBLIC RIGHTS-OF-WAY. THIS MAY REQUIRE TOP

DESIGN (CONT)

DRESSING, REPAIR AND/OR CLEANOUT OF ANY MEASURES USED TO TRAP SEDIMENT.

2. WHEN NECESSARY, WHEELS SHALL BE CLEANED PRIOR TO ENTRANCE ON PUBLIC RIGHTS-OF-WAY.
3. WHEN WASHING IS REQUIRED, IT SHALL BE DONE ON AN AREA STABILIZED WITH CRUSHED STONE THAT DRAINS INTO AN APPROVED SEDIMENT TRAP OR SEDIMENT BASIN.

**SECURITY ACKNOWLEDGEMENT FORM**

In the event that the security required to be paid to obtain an SESC permit and the security is paid in cash, the Landowner and the Designated Agent acknowledge that the cash security will not be returned to the Applicant until the site is considered stabilized. The cash security will be sent to the Applicant that is listed on the Residential Soil Erosion & Sedimentation Control Permit Application.

Acknowledged by Designated Agent:

Acknowledged by Landowner:

\_\_\_\_\_  
Printed Name:

\_\_\_\_\_  
Printed Name

Date Signed by Designated Agent: \_\_\_\_\_

Date Signed by Landowner: \_\_\_\_\_

## ARTICLE II. - CONSTRUCTION MAINTENANCE ORDINANCE

- **Sec. 26-31. - Intent of article.**

The purpose of this article is to prohibit the depositing and accumulation of litter; to provide regulations for the proper handling and prompt removal of litter, garbage, debris, waste material, dust, sand, mud and dirt from construction sites, buildings under construction, and areas, streets, roads, and highways abutting or adjacent thereto; to preserve the public health, safety and welfare; to properly handle and promptly remove such matter which has severe adverse effects on the community by tending to create a nuisance, creating hazardous conditions which may result in injury to persons or property attracting vermin, causing annoyance to residents and other persons who work in or pass through the village, and detracting from aesthetics of the neighborhoods; and to provide regulations for the use of portable toilets on construction sites.

(Ord. No. 109, § II, 6-12-2000)

- **Sec. 26-32. - Refuse bins.**

(a) *Generally.*

(1) *Use.* No person shall place or allow refuse to accumulate outside of a refuse bin.

(2) *Lids.* All refuse bins shall be fitted with lids which shall be kept completely closed at all times, except for times of filling and collection, to prevent the contents of a refuse bin from being dispersed by winds or otherwise.

(3) *Screening.*

a. All refuse bins located in the village must be enclosed or screened from public view. Such screening shall consist of a wall or fence not less than one foot higher than the height of the refuse bins placed therein, which completely conceals its contents from public view, but in no instance shall such screening be less than five feet in height on three sides. Posts or bumpers shall be provided within the enclosure to protect it from damage from the refuse bin. The inside dimensions of the enclosure shall be such as will permit adequate access for refuse collection vehicles as well as completely enclose refuse bins within the three sides so that no refuse bin projects outside of the open side.

b. Screening materials shall consist of any of the following:

1. Masonry.

2. Wood, provided that the wood is cedar, redwood, marine grade exterior plywood, or equivalent of at least five-eighths of an inch (1.5875 centimeters) thickness or other types of wood which have been pressured treated with preservatives. If cedar, redwood, or plywood are used in the screening, it shall be protected from possible rot or decay by the

application of a preservative. Wood that has been pressured treated need not be further protected from possible rot or decay.

3. Evergreen shrubbery consisting of permanent, living plant materials which shall be continuously maintained in a sound, healthy and vigorous growing condition, free of plant diseases and insect pests, and free of weeds, refuse and debris. The shrubbery shall be planted and maintained so as to create a continuous barrier.

c. This article is not intended to require the enclosure of any refuse bin used on a temporary basis during the construction of any building, provided that the refuse bin is removed from the premises or is moved to be approved, enclosed location on the site prior to the issuance of a final certificate of occupancy for the building under construction. This article is not intended to require the enclosure of any refuse bin unless that refuse bin is otherwise visible from a public place, or an area to the general public.

(4) *Prohibited bins.* No person shall place or maintain any refuse bin within the village which is banned as a hazardous product pursuant to part 1301, subchapter B, chapter II, title 16 of the Consumer Product Safety Commission Rules under sections 8 and 9 of the Consumer Product Safety Act 15 USC 2057 and 2058.

(5) *Requirements of owner.* No person shall place or maintain any refuse bin within the village until:

a. The owner thereof or the person placing or maintaining such refuse bin in the village shall file with the village a sworn affidavit or such other evidence verifying that such refuse bin is not a prohibited refuse bin.

b. The owner thereof or the person placing or maintaining such refuse bin in the village shall permanently place on a conspicuous area of such refuse bin such person's name, address, and telephone number.

(6) *Enforcement.* The department of building and safety is hereby charged with the enforcement of this section.

(b) *Refuse collection/removal.*

(1) *Time.* No refuse, whether properly stored or not, shall be kept on a premises for more than one week. It shall be the responsibility of both the owner and the person in control of the premises to properly dispose of all refuse on at least a weekly basis.

(2) *Enforcement.* Upon receiving a complaint or having reason to believe that refuse is not being disposed of in accordance with subsection (b)(1) of this section, an ordinance enforcement officer may request from the owner and/or the person in control of the premises, evidence that such person is employing a refuse collection service which collects refuse on at least a weekly basis, or show a receipt evidencing the power in control of the premises to produce such evidence within one week of receiving a notice of violation, shall constitute in evidence a presumption that the refuse is not being

disposed of in accordance with subsection (b)(1) of this section. The notice of violation shall contain a contact number whereupon a person may obtain a list of licensed refuse collection companies.

(3) *Removal of material.* Material shall not be dropped by gravity or thrown outside the exterior walls of a building during demolition or erection. Wood or metal chutes shall be provided for the removal of such materials. Where the removal of any material will cause an excessive amount of dust, such material shall be wet down to prevent the creation of a nuisance.

(Ord. No. 109, § III, 6-12-2000)

- **Sec. 26-33. - Litter.**

(a) *Legislative intent.* In the development and enhancement of this article it is recognized that proper handling and prompt removal of litter, garbage, debris, waste material, dust, sand, mud and dirt from construction sites, buildings under construction, and areas, streets, roads, and highways abutting or adjacent thereto, is essential to the preservation of the public health, safety and welfare. The failure to properly handle and promptly remove such matter has severe adverse effects on the community by tending to create a nuisance, creating hazardous conditions which may result in injury to persons or property attracting vermin, causing annoyance to residents and other persons who work in or pass through the village, and detracting from aesthetics of the neighborhoods. The purpose of this article is to provide regulations for the prevention of such effects and to provide penalties for the violation of this article, the needs of the community may require expeditious removal of the objectionable matter by the village itself. To this end, a procedure is hereby established by which the village, after due notice is given to the primary contractor or owner of a construction site or building under construction, may remove the objectionable matter and charge the cost of the removal to the owner or party in interest in whose name the subject appeared upon the last tax assessment records.

(b) *Definitions.* The following words, terms and phrases, when used in this article, shall have the meanings ascribed to them in this section, except where the context clearly indicates a different meaning:

*Construction material* means any material used for the purpose of the erection, alteration, repair, reconstruction, conversion, demolition, moving, or equipping of any building or structure, or the excavation, filling, grading or regulation of a lot in connection therewith.

*Construction site* means a lot on which the erection, alteration, repair, reconstruction, conversion, demolition, moving, or equipping of any building or structure, or the excavating, filling, grading or regulation of a lot in connection therewith, is taking place, has taken place, or will take place.

*Debris* means any accumulation of broken or detached matter including, but not limited to, pieces of stone, brick, cement, plaster, lumber, pipe, wallboard, and shingles.



*Garbage* means putrescible animal and vegetable matter.

*Litter* means garbage and debris and all other matter which is thrown, dumped, placed, left or deposited as prohibited in this article, which may tend to create a danger to the public health, safety and welfare.

*Owner* means the person or party whose name appears upon the last tax assessment records of the village.

*Primary contractor* means the person that has obtained the building permit for building on the construction site or the person that is in control of construction on the construction site.

*Street and highway* mean:

- (1) The entire width between boundary lines of any way publicly maintained when any part thereof is open to the use of the public for purpose of vehicle travel;
- (2) The entire width between boundary lines of any way dedicated for public use within a recorded plat irrespective of whether street improvements within the plat have been accepted by the village;
- (3) The entire width of any public or private street contained within a site condominium.

*Waste material* means any putrescible and nonputrescible solid waste, except body waste including, but not limited to, garbage, debris, uprooted vegetation and herbage, tree limbs and stumps and any other matter which, if thrown, dumped, placed, left or deposited as prohibited in this article, may tend to create a danger to the public health, safety and welfare.

(c) *Requirements of person in charge of building site.*

(1) Each contractor who owns, controls or is in possession of a construction site or building under construction shall:

- a. Provide a receptacle at each construction site and building under construction which shall be of sufficient size and dimension to adequately contain such litter, garbage, debris and waste material as may be found at the construction site or building under construction;
- b. Place all litter, garbage, debris and waste material from the construction site within the receptacle;
- c. Place all construction materials within the confines of the lot lines of a construction site or building under construction;

d. Sweep the streets, roads or highways adjacent to the abutting the construction site, or building under construction at least once per week, or more frequently if litter shall be dumped, deposited, placed or thrown on the streets, roads or highways;

e. Maintain the construction site, building under construction, and adjacent area free of litter, garbage, debris and waste material;

f. Maintain the street, road or highway adjacent to or abutting such construction site or building under construction free of dust, sand, mud, dirt, litter, garbage, debris or waste material from the construction site or building under construction.

(2) The failure of a person to comply with the requirements of this section shall constitute a violation of this article. The commission of any of the following acts shall constitute a violation of this article:

a. The dumping, depositing, placing, throwing, leaving or burying or causing or permitting the dumping, depositing, placing, throwing, leaving or burying of litter, garbage, debris or waste material at any construction site or building under construction.

b. The transferring of litter, garbage, debris, or waste material from one construction site or building under construction to another.

c. The dumping, depositing, placing, throwing, leaving, or causing or permitting the dumping, depositing, placing, throwing or leaving of dust, sand, mud, dirt, litter, garbage, debris or waste material on any street, road, highway or right-of-way.

d. The placing of construction materials on any street, road, highway or right-of-way.

e. Refuse, construction materials and equipment shall not be placed or sorted so as to obstruct access to fire hydrants, standpipes, fire or police alarm boxes, utility boxes, catchbasins or manholes, nor shall it be placed so as to obstruct normal observations of traffic or to hinder the use of public transit loading platforms.

f. All refuse materials shall be removed in a manner which prevents injury or damage to persons, adjoining properties and public rights-of-way.

*(d) Cleanup of mud, dirt and debris on streets.* Whenever work or construction in the village causes the deposit of mud, dirt, debris or any other material on a street, highway, pathway, or alley, the developer, builder, contractor and permit holder, as well as the owner of the premises where the work or construction is taking place, shall be responsible for cleanup and compliance with this section. Any mud, dirt, debris or any other material deposited on a street, highway, pathway or alley shall be removed by the end of the workday. However, upon notification from the village to the permit holder that a dangerous condition exists due to the accumulation of mud, dirt, debris or any other material on a street, highway, pathway or alley, the person responsible shall immediately clean the street, highway, pathway or alley within two hours.

(e) *Responsible for cost of cleanup.*

(1) *One person responsible.* If it becomes necessary for the village to clean an accumulation of mud, dirt, etc., from a street, highway, pathway or alley on account of the failure of the person responsible under subsection (d) of this section to do so, the village may perform necessary street cleanup, and the person responsible shall pay to the village the cost of cleanup with a certified check or cash deposit and the person responsible shall pay to the village the cost of the cleanup.

a. *Use of permit cash deposits.* The village may use that cash deposit filed with the village in order to obtain reimbursement for the cost of cleanup.

b. *Immediate replenishment of cash deposit.* If it becomes necessary for the village, pursuant to this subsection, to use a cash deposit on file with the village, the permit holder shall be required to immediately replenish and replace the cash deposit.

(2) *Multiple persons responsible.* If an accumulation of mud, dirt, etc., appears to be the responsibility of more than one person or is related to building or construction activities on more than one site, the cost of cleanup by the village shall be prorated and charged against the cash deposits of all the persons determined by the superintendent of the department of public works to be responsible.

(3) *Lien.* In those cases where deposited funds are insufficient to cover the cost of cleanup performed by the village, or payment has not been received, such costs shall be a lien against the real property and shall be reported by the building official to the assessing officer of the village who shall assess the cost against the property. The owner or party in interest in whose name the property appeared upon the last tax assessment records shall be notified of the amount of such cost by first class mail at the address shown on the records. If he fails to pay the same within 30 days after mailing by the assessor of the notice of the amount thereof, the assessor shall add the same to the next tax roll of the village and the same shall be collected in the same manner in all respects as provided by law for the collection of taxes.

(f) *Enforcement.* In addition to the village's use of certified checks and cash deposits, pursuant to subsection (e) of this section, the building official, upon determining there has been a failure to comply with the requirements of subsections (c) and (d) of this section, may order the stoppage of work, the withholding of inspections, and/or the staying or revocation of the building permit issued for the work site until compliances is obtained.

(Ord. No. 109, § IV, 6-12-2000)

- **Sec. 26-34. - Portable toilets.**

(a) *Definitions.* The following words, terms and phrases, when used in this section, shall have the meanings ascribed to them in this subsection, except where the context clearly indicates a different meaning:

*Portable toilet* means a receptacle for human waste temporarily in a location for human use.

(b) *Prohibited acts.* It is unlawful within the village to keep, maintain or permit to remain on any land zoned residential, commercial or industrial a portable toilet.

(c) *Exceptions.* The prohibited use of a portable toilet shall not apply to those portable toilets allowed and required on construction sites, pursuant to of the Mich. Admin. Code R. 408.40129, or to those utilized at a public park or school facility. No permit is required.

(d) *Toilets at construction sites.*

(1) Toilets at construction sites shall be provided for employees as follows:

a. One to 20 employees, one toilet.

b. Twenty-one to 40 employees, two toilets.

c. Forty-one or more employees, one additional toilet for each additional 40 or less employees.

(2) A jobsite that is not provided with a sanitary sewer shall be provided with one of the following toilet facilities, unless prohibited by local codes:

a. A privy; if use of the privy will not contaminate groundwater or surface water;

b. A chemical toilet;

c. A recirculating toilet;

d. A combustion toilet.

(3) The requirements of this rule for sanitation facilities shall not apply to a mobile crew (i.e., essential public utilities crew) that has transportation readily available to nearby toilet facilities.

(4) To ensure sanitation, a toilet shall be serviced and maintained on a regular basis.

(5) A toilet shall be supplied with toilet paper.

(Ord. No. 109, § V, 6-12-2000)

**IT IS THE  
RESPONSIBILITY OF  
THE APPLICANT TO  
RESEARCH DEED  
RESTRICTIONS AND  
ASSOCIATION RULES!**



VILLAGE OF GOODRICH

7338 S STATE ROAD ~ PO BOX 276 ~ GOODRICH, MI 48438

P 810.636.2570 EX 102 ~ F 810.636.8886